

SERVICE MANUAL
MODELS CSV-3L; CSV-4L
REFRESH MODULE
3321 & 3341

GENERAL

This postmix drink dispenser has been developed as a part of the cooperative service vending program. It is one of several Polyvend machines having office compatible styling for customized vending in small to medium size commercial locations.

This cold drink dispenser module offers up to four different flavors with a dietetic kit (Lo-Cal) standard. All drinks are refrigerated and dispensed at a constant 34° to 38° F. to assure quality in taste and simplicity in equipment.

The module consists of different functional assemblies mounted in a contemporary styled cabinet. These are: the refrigerated dispenser head; syrup tanks; carbonator; coin mechanism; solid state electrical control box; dispenser valves; and regulator/gauge assembly. A twenty pound CO₂ cylinder is required for operation.

SPECIFICATIONS

Overall Dimensions:

Height.....70 inches
Width.....25 inches
Depth.....25 inches
Door Open Clearance.....24 inches

Weight:

Shipping.....432#

Capacities:

Syrup.....3 or 4 three gallon tanks
Dispenser water bath (ice bank).....6½ gallons
Full Ice Bank (approximate).....22 pounds
CO₂ Cylinder (not furnished).....20 pounds

Refrigeration Performance:

Drink temperature.....36° F
Compressor.....1/6 H.P.
Cool Down Time (warm).....6 Hrs.

Electrical:

Primary.....115 VAC-60 HZ
Secondary.....24 VAC
Current (115 VAC).....12 Amps

NOTE: Polyvend, Inc. is not responsible for faulty or overloaded circuits where CSV banks are installed. The exact load imposed by each bank module is stated in the related service manual. The sum of all such modules in any particular location will determine the total load. No one module is designed to carry more than 13 amps at 115 VAC.



THE POLYVEND REFRESH MODULE IS SHIPPED IN TWO CARTONS. THE LARGE CARTON CONTAINS THE COMPLETE MACHINE EXCEPT THE CARBONATOR WHICH IS SHIPPED IN THE SMALLER CARTON.

INSPECTION

- Remove shipping carton from around machine by cutting the steel band at the bottom of the carton and push carton upward.
- Locate key that is taped to the countertop.
- Using the key, open the lower compartment door.
- Pull the sliding tray out and remove all accessory items in lower compartment. Verify that the tanks, corner shelf bracket, and tank mounted regulator/gauges have been included. (If optional water filter was ordered, it will also be packed in lower compartment). (FIG. 1) The Carbonator is packed in a separate carton but it should arrive at the same time the machine does.
- Check machine and accessories for shipping damage.

The above unpacking and checking procedures should be performed immediately upon arrival of each machine. If damage or a shortage is found, a claim should be filed with the carrier.



Fig.1

- * CO₂ Shelf
 - * Regulator/Gauges
 - * Tanks
- (Water Filter Kit - optional)

THE REFRESH SYSTEM

This post-mix system requires three ingredients in order to dispense a drink. These are a potable water supply, CO₂ bottled gas, and concentrated syrup. Refer to the flow diagram, FIGURE 2, Page 4. The water supply is connected to the carbonator where it is pumped at about 200 pounds into the tank and dispersed and saturated with CO₂ gas. The CO₂ is supplied by the use of a 20 pound refillable cylinder. Various regulators control the CO₂ down from bottle pressure to that required for the particular usage. The CO₂ is supplied to the carbonator at about 100 pounds. The CO₂ is also used at the syrup tanks to push the syrup to the dispense valves. Thirty pounds pressure is required for sugar type syrup and about 5 pounds for the diet syrup.

An ice water bath is used to cool both the syrup and carbonated water before it reaches the dispense valves. This is a closed water bath and requires initial and periodic filling with water for proper operation.

The dispense valves regulate and mix the flow of the pressurized syrup and carbonated water. Flow restricters in the valves allow just the proper amount of each to be released for the time specified. This ratio of syrup to water (Brix) is critical to the quality of the drink dispensed.

The flow diagram on the opposite page should be reviewed before installation procedures begin. The diagram shows the flow of water, CO₂ gas, syrup, and carbonated water. The major components are shown with their related lines attached for reference. The regulator/gauge assemblies are also shown with their proper pressure settings. This diagram can also be referred to as a final check after the refresh unit has been installed.

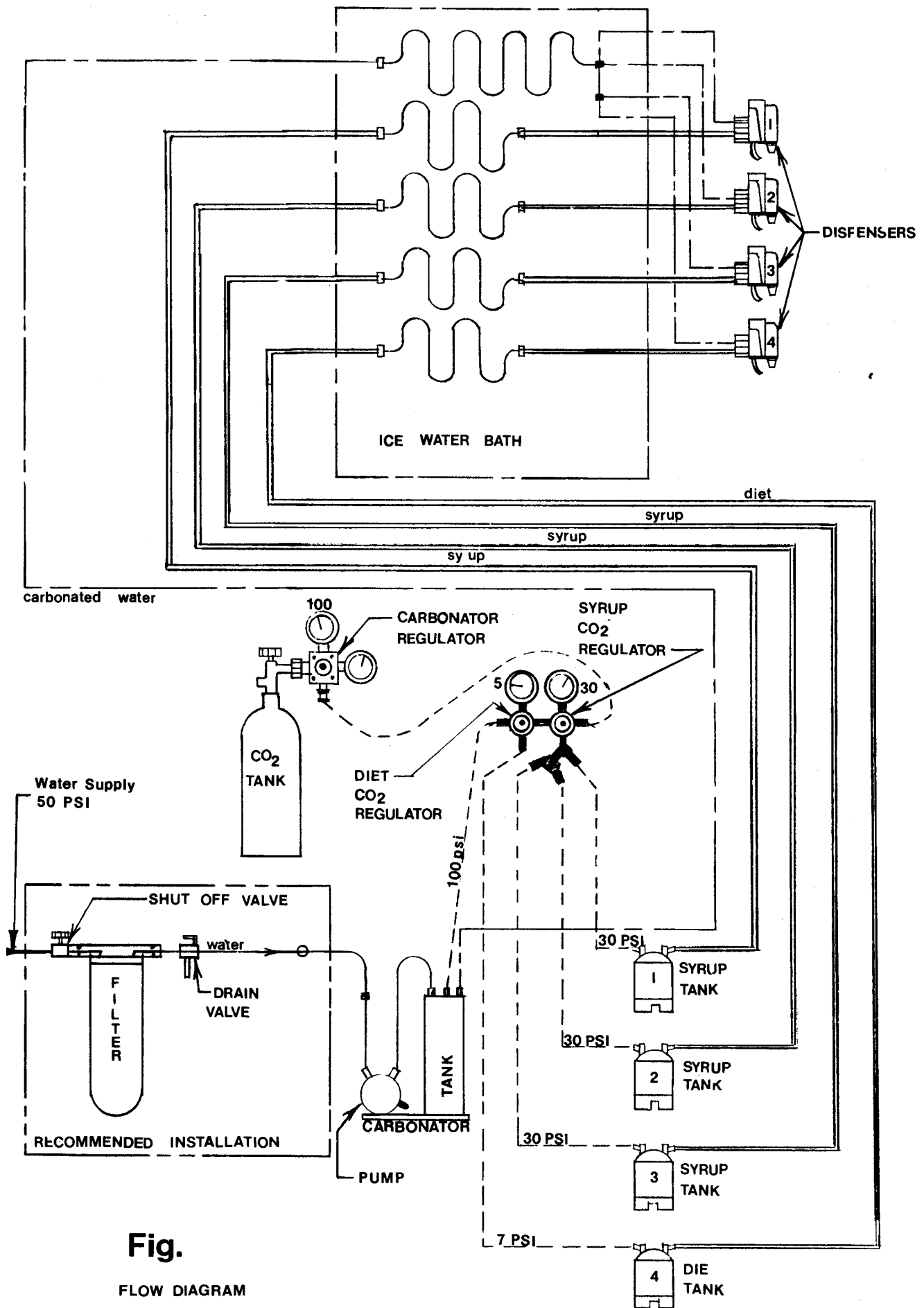
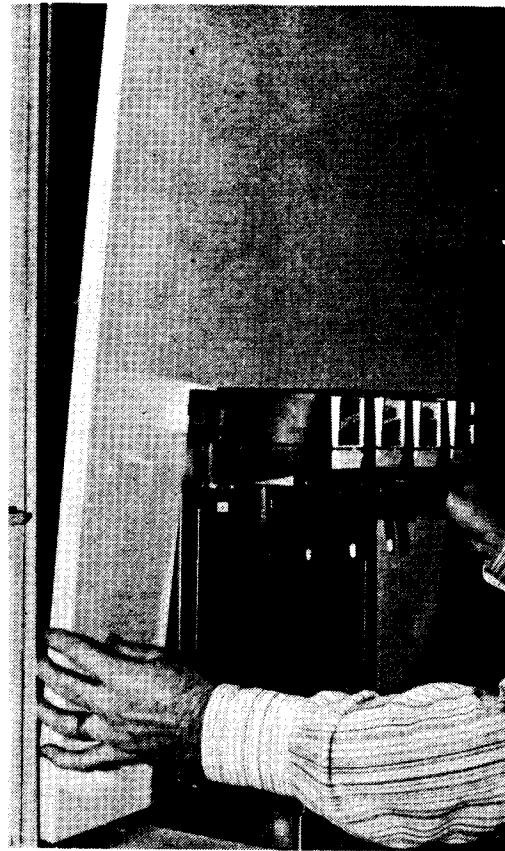

Fig.

FLOW DIAGRAM

Fig. 3



INSTALLATION

The sequence listed below describes a recommended step-by-step procedure for installation. The actual sequence used will vary depending on individual company procedures and customer demands. Because of the time involved, the first concern should be to fill the ice bath with water and plug the machine into a 115V source, so the ice bank can be formed. The ice bank must be stable before the water/syrup ratio (Brix) can be adjusted properly.

- Remove front cowling by prying forward until magnet clip releases, then lift cowling up to clear dispenser valves (FIG. 3).
- Remove the fill plug from the refrigeration unit water fill hole (FIG. 4).
- Remove splash plate (FIG. 5).
- Pour approximately 6½ gallons (25 liters) of clean, low mineral water into the evaporator tank. Proper water level will be attained when the water in the drain tube is ½ inch below hose clip (FIG. 6).

NOTE: If available, use cold water so the time required to form an ice bank can be reduced.

- Replace the fill plug.



Fig.4

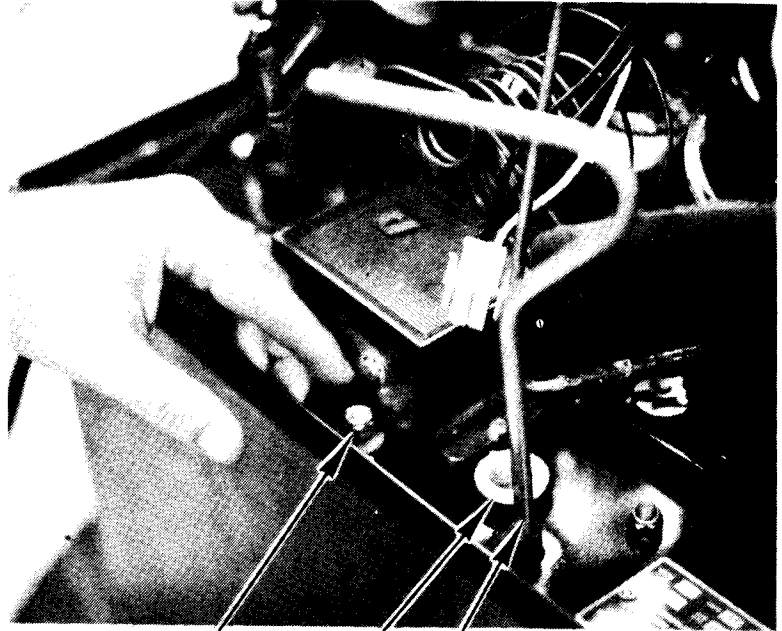

Locknut
Fill Plug
Handle



Fig.5

Splash Plate

Fig.6

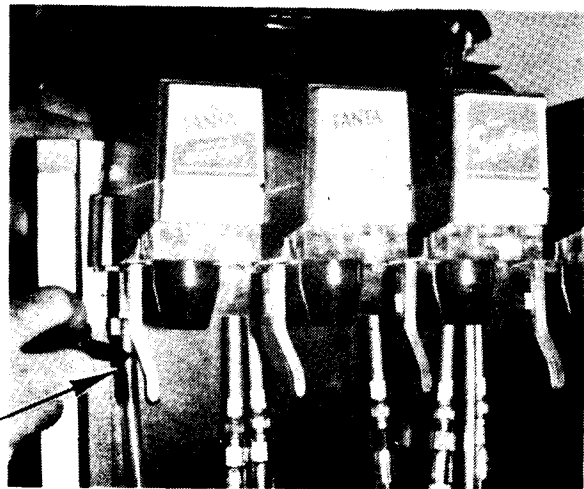

Water Level

- The power cord for the fluorescent light and the cord for the compressor (power deck) are plugged into the junction box by Polyvend before shipment. The service cord (which comes in through the back of the cabinet), can now be plugged into a wall outlet supplying 115V, 60 cycle, fused 15 amps. The compressor will now begin making an ice bank and the fluorescent lamp and correct change light will come on.

- NOTE: The carbonator power cord should not be plugged into the junction box until water is supplied to the procon pump. If the carbonator is allowed to operate while "dry" the pump will be damaged.

- Optional water filter installation (SEE FIGURE 8): Use of filter is recommended by Polyvend. Filter used must have 100 gal/hr flow rate capacity.
 - Locate four holes on the rear of the machine which match the filter wall bracket, and attach it with four #8 x $\frac{1}{4}$ type "B" screws.
 - Insert two #8 x $\frac{3}{8}$ type "AB" screws in face of bracket.
 - Attach "L" shaped bracket to the center of the filter.
 - Hang-assembly on wall bracket.
 - Install $\frac{3}{8}$ " MPT x $\frac{3}{8}$ flare fittings (not included) into the head.
 - Bring inlet and outlet tubing to the head and attach. (Make sure water will flow in direction of arrow on filter.)
 - Install quick change cartridge.
 - Slide machine into position.
 - Turn on water. Flush with 5 gallons of water and shut off at filter.

- CO₂ Tank
 - Mount shelf for CO₂ tank.
 - Unpack boxed shelf and remove three $\frac{1}{4}$ x 20 screws in right back side of lower compartment.
 - Place shelf in position with mounting to the back and up in reference to shelf platform.
 - Align holes and secure with screws removed earlier.
 - Unpack the high pressure (tank mounted) regulator/gauges. (Boxed for shipment).

- Notice that two (2) fiber washers have been attached to the regulator assembly. If a washer is not already inside the swivel nut, insert one (1) of these inside the coupling nut, attach and tighten regulator assembly to fresh, 20 pound tank of CO₂. The tank is not supplied with refresh module but may be secured from local sources. (FIG. 7)

CAUTION: Bottled CO₂ can be a very hazardous material if not handled and transported properly. If unfamiliar with characteristics, request additional information from local sources or Polyvend.

- Attach hose from right side of low pressure (wall mounted) regulator/gauges to the bottom fitting of the high pressure (tank mounted) regulator assembly (FIGURE 9). Be sure white tapered gaskets are used on all fittings for tight connections.
- Place CO₂ tank on shelf and secure with chain provided.(FIGURE 9)

Fig. 7

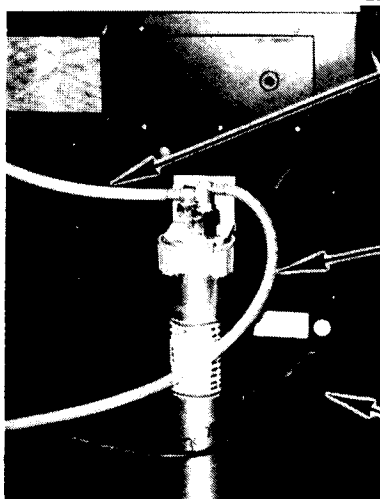
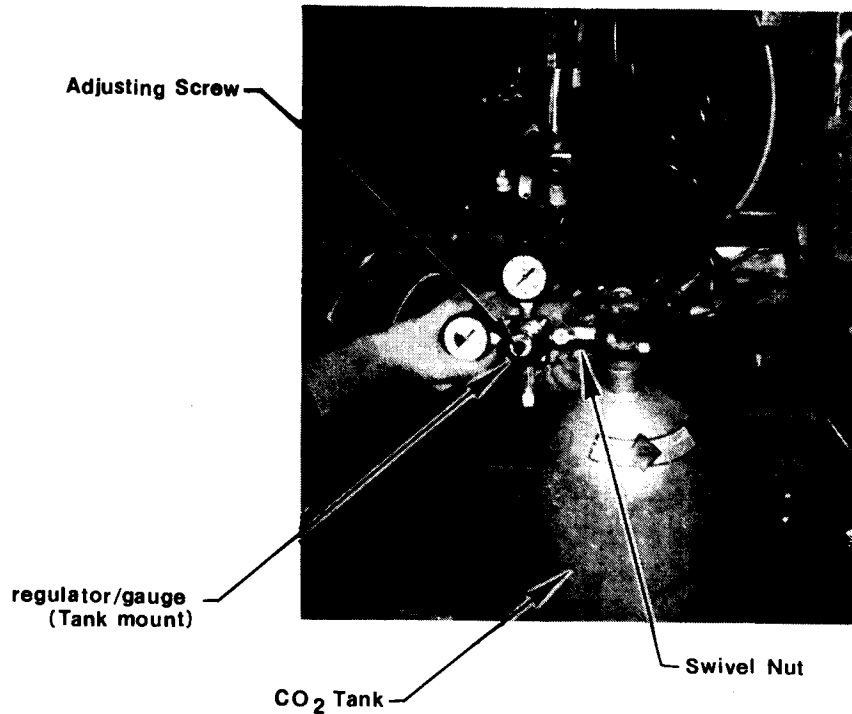

Hose #2: Filter to Carb. Pump

Hose #1: Water into Filter

Route Hose #2 Through Hole

Fig.8



Fig. 9

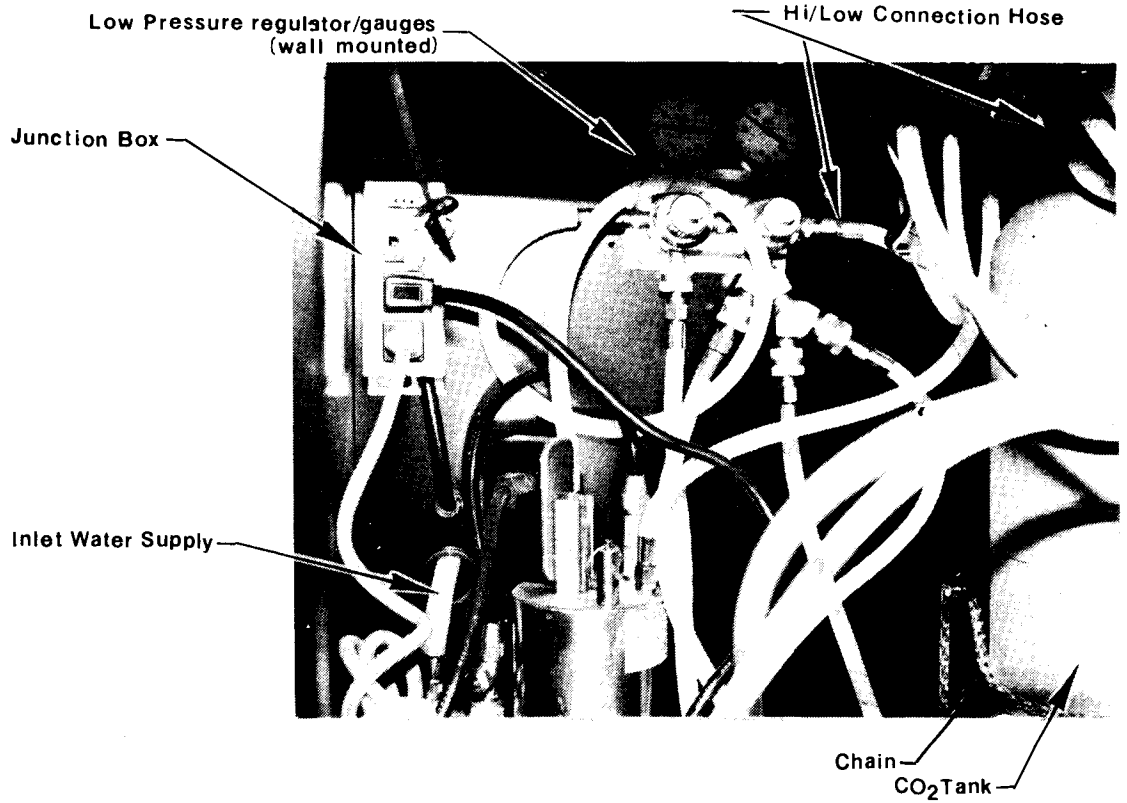
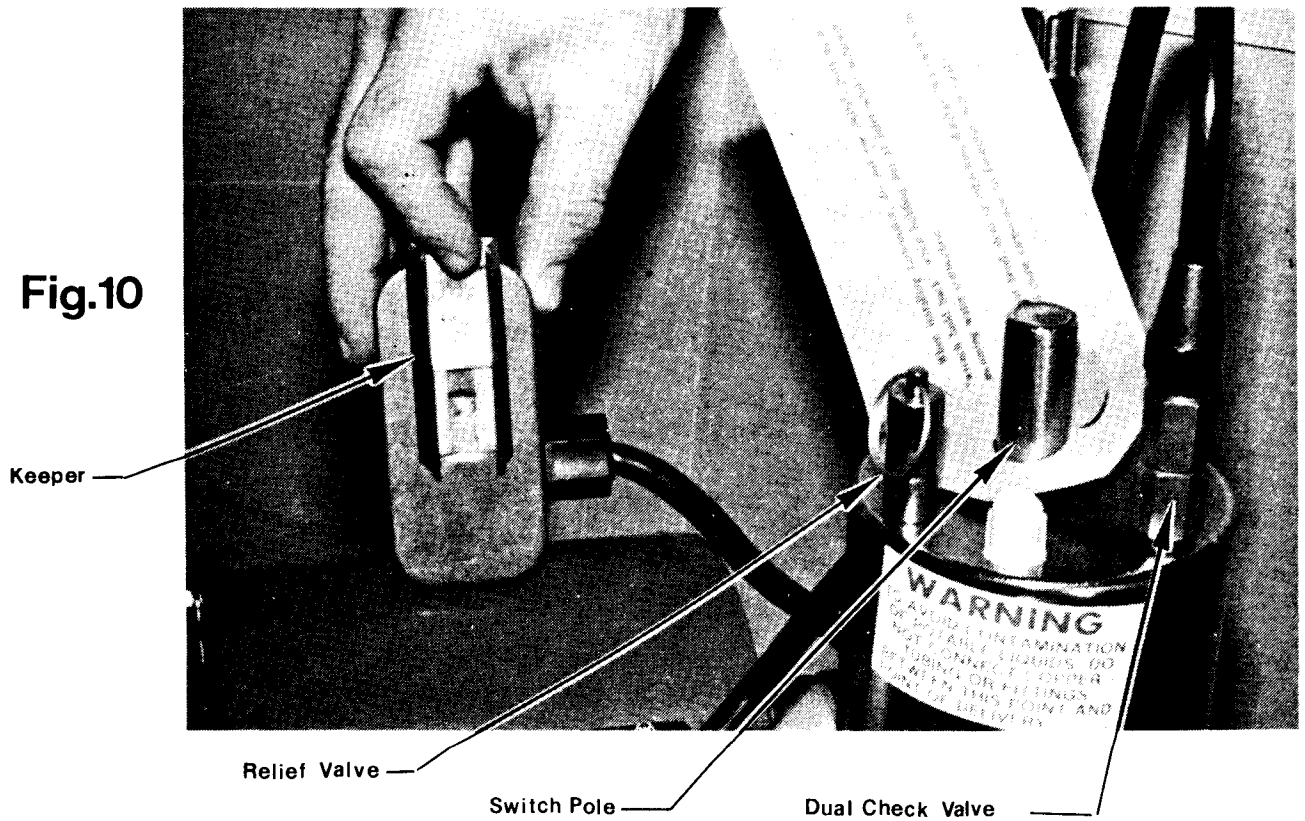

Fig.10



CARBONATOR

- Unpack carbonator and place for connections on left shelf in lower cabinet with pump and tank toward the back. DO NOT plug into junction box until water is supplied to the carbonator. Note that the magnetic carbonator switch has a metal keeper in the slide bracket that must be removed (FIGURE 10).
- Push long end of carbonator switch clip on switch pole of carbonator tank (FIGURE 9), and position all the way down to top of tank.
- Attach water inlet hose (coming from water filter) to the black inlet hose on the Procon pump. See "water supply" Page 21.
- Attach the hose coming from the left side of CO₂ low pressure (wall mounted) regulator assembly to the inlet fitting marked "gas" on top of the carbonator tank.
- Locate white braided hose that comes down through the hole in the center of the countertop. It has an open fitting that connects to the outlet fitting marked "soda" on top of the carbonator tank.
- Be sure all connections are tight and slide carbonator all the way to the back of the left hand shelf. Route all power cords and connecting lines so as to be out of the way and not against pump or motor.

WATER SYSTEM SETTINGS

- Turn water supply "On": (If optional filter is used, turn lever to "On" by placing lever in horizontal position.
- Pull up relief valve on top of carbonator tank for 3 seconds to expel trapped air.
- Plug carbonator power cord into junction box on back wall. Carbonator should cycle on and off in less than one minute running time.
- Open valve on CO₂ tank - slowly until the high pressure gauge needle has stopped, then open valve fully until the valve "back seats".

NOTE: The CO₂ tank valve is a "dual seat" valve - that is it seats when closed and when fully open. The CO₂ is under high pressure and can leak around the top of the valve unless the valve is opened fully and "back seats".

- Set CO₂ tank mounted low pressure gauge (0-160) on 100 psi by turning regulator screw (FIG. 7) in (clockwise) until needle points to 100.
- Actuate each dispenser valve until a smooth flow of water is dispensed.



The next step is to adjust all dispensing valves so they dispense the same amount of carbonated water within the same time span (5 ounces in 5 seconds or 140 grams in 5 seconds).

- To measure and adjust water throw:
 - In lower cabinet, turn free vend switch to "coins".
 - Establish credit on machine and measure dispense cycle time at any of the valves.
 - Adjust dispense time to 5 seconds:
 - Remove cover on control box in lower cabinet.
 - CAUTION: SOME CIRCUITS INSIDE THE CONTROL BOX ARE 115 VOLTS.
 - Inside, locate the two white adjusting screws toward the front of the control box (FIGURE 11). These can be identified by the single digit numbers beside each screw head.
 - The top screw controls units and the bottom screw - tenths of units.
 - The higher number of each reflects more throw time. Normally 3.8 registers a 5 second cycle. Adjust each until the 5 second cycle dispense time is set.
 - Purge water lines by dispensing water until carbonator cycles on and a steady flow of water is dispensed.
 - Establish credit on machine, catch and measure water dispensed during a complete cycle from one of the valves. Should be 4 3/4 to 5 1/4 ounces.

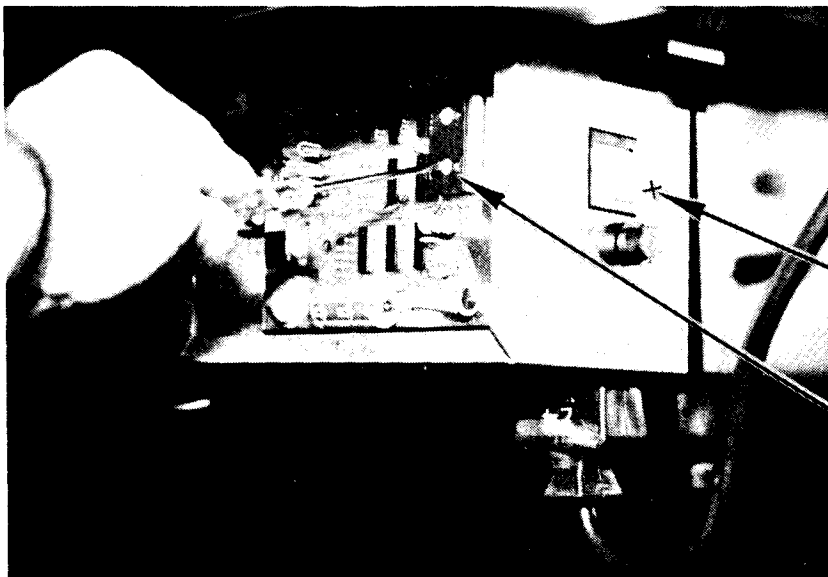

Fig.11

Control Box

Product Throw
Adjusting Screws



- To adjust water throw:
 - Remove cover on dispensing valve by loosening the screw (FIGURE 12) and lifting straight up.
 - Locate adjustable flow controls on top of valve (FIGURE 12). One is for syrup and the other for carbonated water - labeled "W" and is on the left facing machine. Do not confuse flow controls with shut-off screws. The flow controls are directly behind the valve solenoids and have lock nuts.
 - If necessary, adjust water throw for this valve to the 5 ounce setting by loosening lock nut on water flow control and turning slotted screw in (clockwise) for more or out (counterclockwise) for less.
- Measure and adjust water throw for the other dispensing valves.
- Check all connections for leaks.

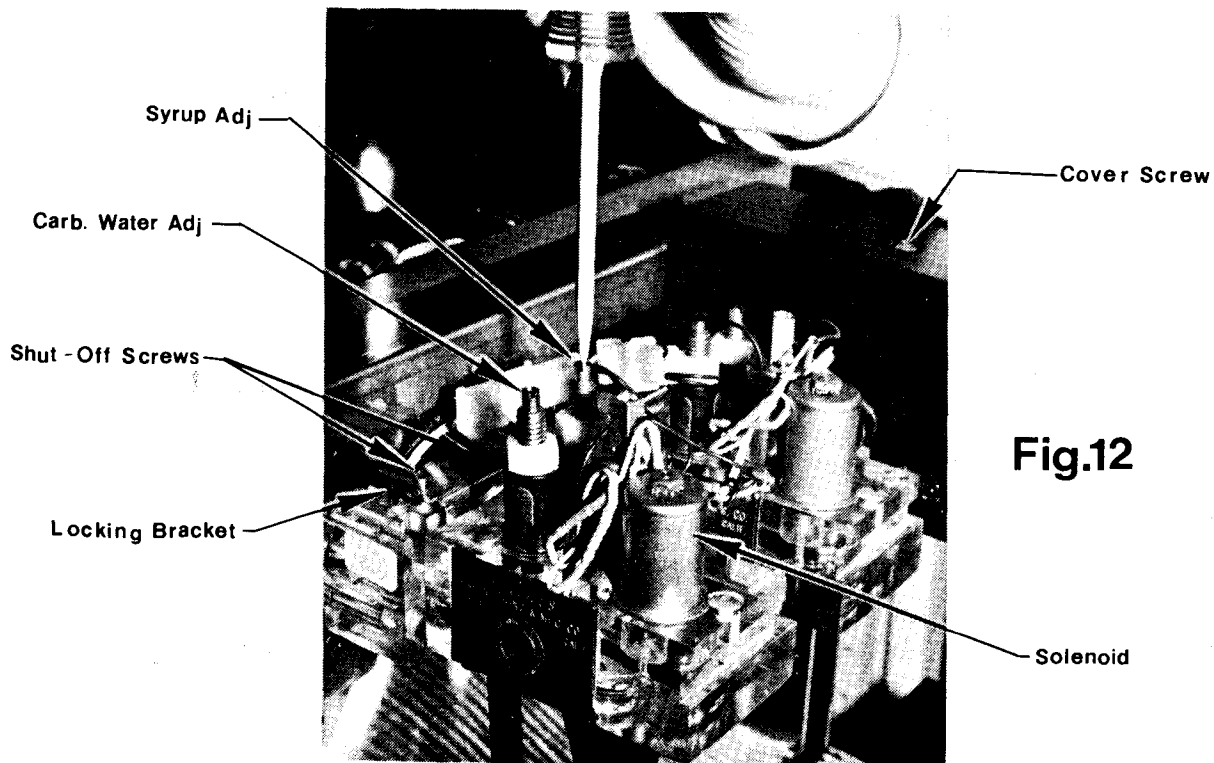

Fig.12

PRODUCT LOADING AND SETTINGS

- To prepare syrup tanks:
 - Unpack syrup tanks.
 - Remove tank lids by pulling up on the wire latches. When the wire latch is released, the cap must be rotated 90° and the end angled upward to remove. Make sure the large "O" ring seal is removed with the lid.
 - Clean and sanitize the syrup tanks and lids.
 - Fill syrup tanks with product and label each tank. (Cola, orange, diet, etc.)
 - Wet "O" ring on tank lid with water and reinstall lid on filled tank. (Note: allow about three (3) or four (4) inches of air space at top of tank when tank is full.) *on 5 1/2 diet*
 - To lock in place, press down on wire latch until it is flat against tank top.
- Connect syrup tanks and adjust CO₂ pressure:
 - Separate and identify quick disconnects and hoses inside lower cabinet. Note that half the quick disconnects have 2 slotted swivels and grey colored inserts and half have 3 slotted swivels and black colored inserts. Also note that each hose has a number on it from one to four. This number relates to its perspective dispensing valve up on the head - #1 being the right hand valve and then numbered right to left, when looking at the front of machine. There should be one of each type quick disconnect for each number.
 - Note that the syrup tanks have two fittings for connections - labeled "IN" and "Out". The "In" fitting is for connecting the two slotted quick disconnect CO₂ gas line. The "Out" fitting has three locators and will accomodate only a three slotted quick disconnect or syrup line.
 - It is recommended for marketing purposes that the #1 or right dispensing valve be connected to the most popular flavored syrup tank. Since the #2 and #3 positions also have the higher CO₂ pressure, they should be used for sugar type syrups too. The #4 or left dispensing valve is equipped for low pressure application of diet type syrups.
 - Adjust CO₂ regulators mounted on back wall to proper settings.
 - Identify regulator and gauges. Note that the regulator with 3 hoses connected to the bottom has a 0-100 psi gauge and the regulator with one hose to it bottom has a 0-30 psi gauge.

- Adjust 0-100 psi gauge regulator by turning center screw in (clockwise) until needle reads 30.
- Adjust 0-30 psi gauge regulator by turning center screw in (clockwise) until needle reads 5. This is for dietetic type syrups. A regular sugar syrup may be dispensed by adjusting to 30 lbs. also.
- Connect gas and syrup lines to their perspective syrup tanks. RECOMMEND WETTING END OF DISCONNECT FOR EASIER CONNECTION TO TANK FITTING O-RING. When the gas lines are connected, a detectable sound of charging will be heard. Check for leaks.
- Position syrup tanks in lower compartment. Because more often filling is required on the most popular flavor, place the #1 syrup tank toward the front of the slide-out tray. The #4 or diet syrup tank should be placed on the left hand shelf just in front of the carbonator.
- Route gas and syrup lines so as to have easy operation of slide-out tray.
- Turn free vend switch in lower cabinet to "free".
- Dispense from each dispensing valve to purge all lines of air and get syrup up into the ice bank coils for cooling. Allow about 5 minutes for cooling of syrup.
- Check temperature of dispensed drink:
 - Dispense a cup of product and immerse thermometer into liquid to stabilize. Gently stir thermometer in liquid.
 - Dispense second cup and take temperature immediately. Reading should be below 40^oF.

NOTE: Brix adjustments should be made only when machine has reached and maintains the proper temperature. The syrup gets thicker at lower temperatures and this effects the flow of syrup and therefore could change the syrup to water mixture after adjustments have been made.

BRIX TESTING AND SETTING

The Polyvend Refresh Module is a "Post Mix" carbonated beverage machine. This means the carbonated water and flavored syrup are mixed at the time they are dispensed from the delivery valve.

In order to assure a quality drink, the proper ratio of carbonated water to syrup must be dispensed. This ratio is called the "Brix". The proper brix is a 5-1 ratio of water to syrup.

To brix, a diverter tube and split cup is required (FIGURE 13). The split cup has two or three chambers. The center chamber is where the carbonated water is dispensed. The side chamber (5 to 1 ratio) is where syrups are dispensed. The other side chamber (5.5 to 1; if present) is not used. The type diverter needed depends on the type dispense valve used (Dole or McCann).

To install diverter tube, remove spout by twisting counterclockwise until notches on shoulder are aligned with retaining screws on valve and then pull straight down. Place the diverter tube on the valve to replace the spout that was removed. Be sure the diverter tube is pushed "up" to seal around the top gasket and then locked by twisting clockwise to position shown in FIGURE 14.

After installing diverter tube, dispense approximately 6 ounces of product into the split cup. If the syrup level and water level are equal, that dispenser is properly brixed (FIGURE 14).

- If split cup chambers did not fill at the same rate, adjustments must be made to the syrup flow control adjustment on top of the valve. (The carbonated water flow control should not be re-adjusted since its flow rate was set earlier at 5 ozs. in 5 seconds.)
- Locate syrup flow control just behind solenoid on top of dispensing valve. It is the one on the right-hand side facing machine and is marked "S". Again, do not confuse with shut-off screws on mounting block. (FIG. 12)
- To increase syrup flow, loosen the locking nut and turn the adjustment in clockwise. To decrease syrup flow, turn screw counterclockwise out.
- After adjustment, remeasure and re-adjust if necessary to get proper brix setting.

NOTE: After split cup has been filled, be sure all syrup has been emptied from cup chamber before re-measuring.

- Repeat for each valve.
- After each valve has been "brixed", replace all covers and spouts over valves.

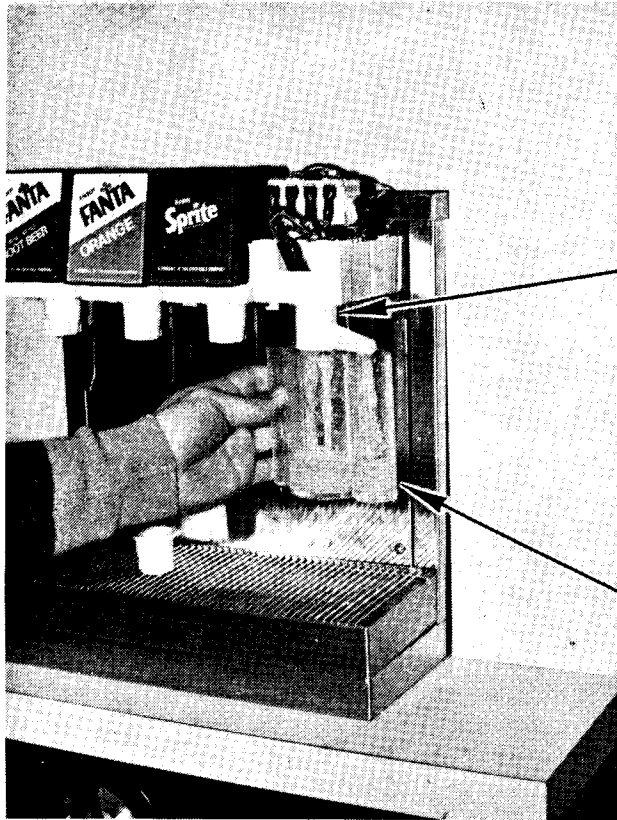

Diverter Tube

Fig.13

DOLE VALVE

Brix Cup

Fig.14
McCann Valve

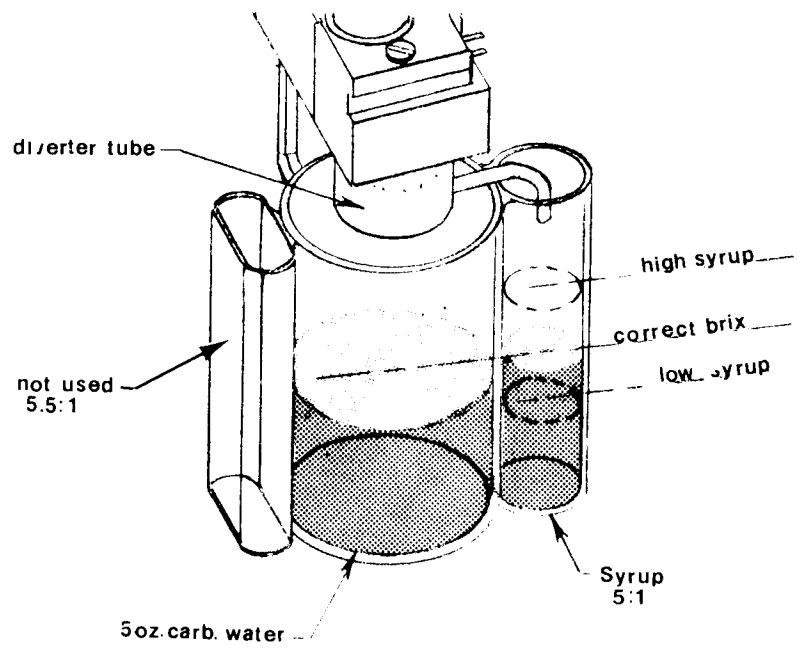

diverter tube

not used
5.5:1

5oz. carb. water

high syrup

correct brix

low syrup

Syrup
5:1

PRODUCT THROW SETTING

The amount of product to be dispensed on each cycle can now be set. This is controlled by the setting of the electronic timer in the control box located in the lower compartment (FIGURE 11).

CAUTION: SOME CIRCUITS IN THE CONTROL BOX ARE 115V.

- To set, remove two screws holding the cover on the control box and remove the cover.
- Locate the two white adjusting screws toward the front of the box. The top adjusting screw reflects a relative setting in seconds and the lower screw is in tenths of a second. Normally a time cycle of 3 and 8 tenths will dispense a 6 ounce drink. A setting of 5 and 1 tenth will usually equal an 8 ounce drink. (Figures are approximate.)
- With the free vend switch in the "coin" position, establish credits and check each valve for desired product throw. Since all valves are controlled by the same electronic timer, any variation would be due to flow rate differences of the water and syrup systems to the particular valves.

FINAL PREPARATION

- Load cup dispensers:
 - Adjust throat springs of cup dispensers to desired cup size. With a cup as a pattern, tighten or loosen four retaining nuts of throat springs until sufficient retention is set on lip of cup. Distribute retention evenly around tube. The tubes may be manually rotated for access to all retaining nuts during adjustment.
 - Insert stack of cups into tubes open end first. Push cups inward until the last one is retained by throat springs.
- Load coin tubes:
 - Insert determined amount of coins in each coin tube. Cycle manual payout to get coins into position and also to check operation. Correct change light should go out.
 - For detailed information on coin equipment, refer to brochure shipped with unit or contact Polyvend or local branch of coin equipment manufacturer.

- Replace all covers and cowling:
 - Replace front cowling (FIGURE 3).
 - Replace splash plate (FIGURE 5).
 - Replace control box cover in lower cabinet.
 - Replace any other parts removed for installation.
- Level machine in place with all four adjusting legs in contact with the floor.
- Look at all CO₂ pressure gauges to verify proper settings: 0-30 gauge reads 5-7 psi;² 0-100 gauge reads 30; 0-160 gauge (tank mounted) reads 100 psi; the 2000 psi gauge registers above red area.
- Perform CO₂ leak test: turn valve of CO₂ tank off and watch the 2000 psi gauge on tank to see if the needle drops.² If no drop is detected, there are no leaks in the CO₂ system. If a leak is detected, refer to trouble shooting section described later in this manual.
- Check routing of all hoses and power cords to see that they are not binding or pinched anywhere.
- Close and lock bottom door. Check operation by inserting various coin combinations and dispense all selections. Note that flavor and amount dispensed and also that change payout are correct.

ELECTRICAL

The Refresh Module operates on a primary power supply of 115 VAC 60 Hz. The refrigeration, carbonator, and overhead lamp subsystems all operate from this primary supply independent of each other. A transformer is utilized in the solid state electrical control box to step down the primary to a 24 VAC supply for the coin mechanism and dispense valves. This is done principally for consumer safety. The complete wiring diagram is shown in FIGURE 16 Page 29A.

A 3 position VAC junction box is located on the back wall of the lower compartment for connecting the components requiring this primary voltage. Plugged to this junction box are the overhead lamp, the carbonator, and the electrical control box.

The overhead lamp consists of a ballast, a starter, and a fluorescent tube. The tube is accessible by sliding back the white diffuser that is retained by the two elbow catches (see parts breakdown, page 33). The ballast and starter are located up on the inside back of the lamp fixture. In all cases the front cowling must be removed to gain access.

The carbonator consists of a reservoir tank and a pump driven by an electric motor that is controlled by a level switch. It's purpose is to carbonate water by forcing CO₂ into the water under pressure and holding it for dispensing. The magnetic level switch is activated by a float that is positioned by the water volume in the carbonator tank.

The refrigeration system consists electrically of a compressor with starter relay and overload protector; a condenser fan and motor; an ice bank control; and an agitator blade and motor. The refrigeration system is plugged to a 115 VAC receptacle on the back of the electrical control box. A closed junction block on the refrigeration power deck is used to distribute power to the deck components. The agitator motor is connected directly to this 115 VAC and runs continuously. The compressor and condenser fan motor are regulated by the ice bank control. The "on-off" cycle of this control is determined by whether or not ice is formed around the end of the bulb that is positioned in the ice bank. The position of this bulb therefore determines the size of the ice bank. A starter relay is used on the compressor to surge the power each time the refrigeration cycle is called for by the ice bank control. A thermal overload device is mounted against the outside of the compressor and is heat sensitive. It is wired in series with the compressor and any overheating will result in shutting off the compressor to prevent permanent damage.

The electrical control box is mounted on the right inside of the lower compartment. It consists electrically of a 115 VAC to 24 VAC step-down transformer, solid state circuit board, fuse, free vend switch, counter, power cord, 115 VAC receptacle and necessary wiring and connectors. The box gets power from the plug connected to the 115 VAC junction box in the back of the machine. This same 115 VAC is connected to the single receptacle on the back of the control box for power to the refrigeration system.

This 115 VAC is fused to the primary side of the 24 volt step-down transformer for protection. The stepped down 24 VAC is then used by the solid state circuit board to control the coin mechanism and the dispense valves. This board gets its vend pulse from either the coin mechanism or the free vend switch. When working from the coin mechanism, the board counts the dispense time and powers the dispense valves only for the time set by the two product throw adjusting screws on the board. The counter is cycled for each drink dispensed. The free vend switch turned to "free" powers the dispense valves so that a continuous drink can be drawn. The counter is still cycled once for each amount determined by the two product throw adjusting screw setting.

The coin mechanism, correct change light and free vend light all connect to the electrical control box. They are 24 VAC components and the lights are lit when the subsequent circuits demand it.

The dispense valves also operate on 24 VAC and are controlled by the electrical control box. When powered from the electrical control box, the dispense switches can be activated by the cup lever. Each switch is connected to the solenoids on the valve. When activated, the solenoids pull up their armatures that open the flow of syrup and water into the cup.

WATER SUPPLY

While most approved water supplies will produce excellent tasting product, a few checks will insure a quality product, customer satisfaction, and minimum service calls.

The water supply should be low mineral content but not "softened" by chemicals or filtration means. Softened water will result in excessive foaming. The water supply should not be "hot". Some locations may have a water supply that comes through pipes that are exposed to the sun or run across the top of a roof where high temperatures are reached.

The water system must be capable of supplying 100 gallon per hour or (1 2/3 gallons per minute). If a lower flow rate exists the carbonator pump can be damaged. The water pressure should be checked by attaching a water pressure gauge to the supply hose and turning the water on fully. The pressure should be 20 psi minimum to 65 psi maximum. If water pressure is too high, CO₂ cannot enter carbonator tank and carbonation will not occur. To reduce water pressure that is in excess of 65 psi, install a water regulator kit and adjust to 50 psi which is the ideal pressure.

NOTE: In some industrial areas, water pressure may be low in the day and high at night due to usage during the day. If the machine is installed in an area where water pressure fluctuation is excessive, a water regulator kit must be installed where pressure is above 65 psi. This will insure carbonation by preventing water pressure to reach the CO₂ pressure.

A water filter is recommended and offered as an option with the module from the factory. Experience has shown that the extra expense of the water filter more than pays for itself in a short time. The filter not only prevents particles from causing mechanical failures, but in some cases, results in a better tasting product.



SPECIAL MAINTENANCE (SEE FIGURE 15)

WARNING

The Carbonator water strainer screen and dual check valves must be inspected and serviced at least once each year under normal circumstances, and after any water supply disruption that could cause stoppage or erratic flow through the system. A carbonator with no screen, or a defective screen in the strainer would allow foreign particles to foul the dual check valves. CO₂ gas could then back flow into the water system and create a health hazard.

To perform maintenance on the carbonator water strainer screen:

- Unplug carbonator assembly power cord from 115 VAC power inside the cabinet.
- Close (clockwise) the CO₂ cylinder valve, then turn off the water supply to the carbonator.
- Pull up on carbonator tank relief valve to relieve system pressure.
- Disconnect all three lines from the carbonator fittings, save all gaskets.
- Loosen screen retainer and pull retainer and screen from pump.
- Pull screen from retainer. Clean any sediment from retainer and retainer port of pump.
- Clean screen and inspect. If there are holes, corrosion or other damage visible, replace with a new screen.
- Check O-ring on screen retainer. Replace worn or damaged O-ring.

WARNING: FAILURE TO USE SCREEN CAN CAUSE DAMAGE TO DUAL CHECK VALVE.

- After replacing screen in retainer, replace in water pump and tighten securely.

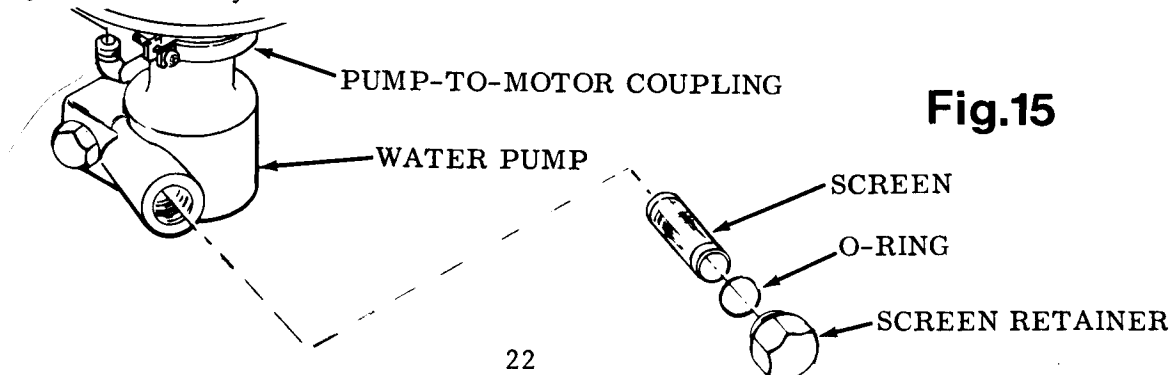

Fig.15

ROUTINE SERVICE AND CLEANING

● Periodic

NOTE: To clean most components, use carbonated water. To get carbonated water, unhook the syrup line from a tank in the lower compartment, turn free vend switch to "free", and activate the dispenser valve which was unhooked at the tank. Carbonated water will be dispensed.

- Clean the cup rest grill and drip tray by soaking them in carbonated water and wiping with a cloth. The grill may be separated from the drip tray for ease of cleaning.
 - The dispenser spout can be removed by pulling it down while gently twisting. It should be soaked and rinsed in warm water or carbonated water only. DO NOT use detergent because it will cause product foaming when reinstalled.
 - The outside cabinet should be wiped with a damp cloth to remove dust and product spillage.
 - When syrup tanks are filled, wipe the lid "O Ring" and the (2) connectors with a clean damp cloth to remove syrup. If the O-ring is not cleaned, the ring may stick to the tank when the lid is removed, and then fall into the tank.
 - The syrup tanks rest on a sliding tray that should be wiped with a clean cloth to remove syrup spillage each time the tanks are filled.
- Every 6 Months

Tanks, syrup lines, and valves should be sanitized every 6 months. The syrup in the tanks thickens and forms a "ring" on the side of the tanks after 4-6 months. When fresh syrup is added to the tank, the old syrup does not mix. Therefore to insure proper taste, they must be cleaned.

- In order to clean the syrup flow system, disconnect and remove syrup tanks from the cabinet. De-pressurize and rinse each syrup tank. (Do not use detergent solution.)
- Fill one tank 3/4 full with 170^o - 180^o water. Dissolve 8 to 10 ounces of baking soda in the water.
- Pressurize the tank with a CO₂ line and connect the syrup line from #1 valve to the tank.
- Open dispensing valve and draw until syrup has been flushed from the system. Repeat for each valve.
- Refill tanks with syrup and reconnect to proper valve. Dispense product until syrup comes through valves.

- At this point, the syrup tanks, syrup circuits, and valves should be thoroughly clean.
- If the brix of the machine has not been checked since initial installation, it is suggested that a check be made while on location.
- If water filters are used, the filter cartridges should be changed in accordance with the filter manufacturers recommendations.

NOTES

TROUBLE-SHOOTING

Due to the solid state circuit board used in the control box, the maintenance and repair of the electrical system of this refresh module is greatly simplified. In most cases, malfunctions can be corrected by replacing this board that is held in its connector by two screws.

- MACHINE WILL NOT ACCEPT COINS
 - Check acceptor/rejector in top of coin changer for full release or being "dirty".
 - Operate manual payout on coin changer.
 - If payout does not operate:
 - Check that machine is plugged to 115 VAC (Is overhead fluorescent lamp on?)
 - Check that control box power cord is plugged into junction box on back wall of lower cabinet.
 - Check that fuse in control box is not blown.
 - Check for defective circuit board in control box by replacing.
 - Check that all connectors on control box are plugged securely.
 - Check that changer is proper type (24 volt).
 - Check for defective changer by replacing with one known to be good.
 - Check that 24 volt stepdown transformer is good. Should read 24-30 VAC between positions #1 and #2 at Jones Plug receptacle on control box.
 - If payout does operate (but crem coils are dead):
 - Bad connection in control box from position #6 to #1 at Jones Plug receptacle.
- MACHINE ACCEPTS COINS, BUT NOTHING WILL DISPENSE:
 - Turn free vend switch to "free" and make selection.
 - If machine now operates:
 - Check for defective coin changer.
 - Check for defective circuit board in control box.

- If machine still does not operate on free play:
 - Check that all wire harness plugs and receptacles are plugged securely.
 - Check for defective circuit board in control box.
- SOME SELECTIONS DO NOT DISPENSE ANYTHING:
 - Defective circuit board in control box.
 - Loose wiring to those dispense valves not operating.
- WATER OR SYRUP NOT DISPENSED OR ERRATIC ON ANY ONE SELECTION:
 - If syrup not dispensed.
 - Check syrup supply. (Are syrup disconnects secure?)
 - Check CO₂ supply and regulator gauge readings.
 - Defective solenoid on dispense valve. Left one is water, right is syrup.
 - Defective flow control on dispense valve. Remove and clean or replace.
 - Check syrup and water fittings and connections.
- WATER NOT DISPENSED ON ANY SELECTION:
 - Check water supply.
 - Check water filter cartridge and shut-off valve.
 - Check that ice bath is not frozen solid caused by defective ice bath control.
- DISPENSED PRODUCT TOO WARM:
 - Check that refrigeration unit is plugged securely to the back of the control box.
 - Check the water level in the ice bath. A gurgling sound means low water.
 - Check that no air restrictions are present around the condensor coils of the refrigeration unit. Be sure they are clean and not bent or mutilated.

- Defective ice bank control - indicated by compressor and condensor fan not running at all.
- Defective agitator motor or missing blade.
- Low freon charge of refrigeration unit indicated by:
 - Excessive operation of compressor.
 - Frost on capillary tube.
 - Hot evaporator coils on top and bottom (ice forming coils).
 - Ice on ice bank small at top and large at bottom.
 - Oil on unit indicating leak in freon system.
- Check that compressor is operating properly:
 - If short cycling off and on:
 - Check that condensor fan motor is running when compressor does.
 - Check for malfunctioning thermal overload device. NOTE: Check for low voltage condition before replacing thermal overload.
 - If compressor does not run when condensor fan does - starter or compressor is defective.
- DISPENSED PRODUCT TOO FOAMY:
 - Check CO₂ pressure settings:
 - Carbonator regulator on CO₂ bottle set at 100.
 - Sugar syrup regulator (on back wall with three hoses) set at 30.
 - Diet syrup regulator (on back wall with one hose) set at 5-7.
 - Check dispensed product temperature - must be below 42^oF for acceptable foam level. If not, refer to section above.
 - Dirty or contaminated dispense valve - disassemble and clean.

- Syrup tanks may have been shaken causing saturation of syrup with CO₂. Relieve CO₂ pressure and open syrup tank for a few minutes to allow escape of carbonation.
- PRODUCT CARBONATION TOO LOW:
 - Check CO₂ pressure setting to carbonator (regulator on CO₂ tank).
 - Water pressure too high - should be lower than 65 psi. Install pressure regulator on water supply.
 - Air trapped in carbonator tank - vent through relief valve and cycle carbonator 2 or 3 times.
 - CO₂ supply low or contaminated - replace with fresh supply and flush out system.
 - Incoming water temperature too high - will deter proper carbonation.
 - Incoming water contaminated or too high in mineral content - install filter or replace cartridge.
 - Defective carbonator component - motor, pump, switch, or check valve.
- AMOUNT OF PRODUCT DISPENSED VARYING FROM CUP TO CUP:
 - Defective circuit board in control box.
 - Recheck flow control settings on dispense valves - especially water flow rate.
 - Low CO₂ supply - check for leaks.
- EXCESSIVE USE OF CO₂: - A 20 lb tank should supply about 25,000 ounces of finished product. A leak can be detected by simply turning main valve on CO₂ tank off and watching the 2000 lb gauge on tank. If the needle drops in its reading, there is a leak in the system. Follow the procedure below to isolate the leak and refer to the flow diagram, FIGURE 2 Page 4.
 - Disconnect all syrup tanks at the "in" or gas side quick disconnect. Repeat above test.
 - If the needle does not drop, the leak is in the syrup delivery system from the syrup tanks to the dispense valves. This type leak is usually indicated by syrup spills or seepage. The particular selection may be isolated by reconnecting each quick disconnect one at a time and repeating above test. (Sometimes the leak may be at the O-ring on the quick disconnect fitting and only leak when the quick disconnect is pulled to one side. Another suspect area is the diet syrup tank. Because of its low tank pressure, a dry and dirty tank lid O-ring will result in a poor seal and a slow leak.)

- If the needle on the 2000# gauge does drop on the test above, the leak is in the CO₂ delivery system from the CO₂ tank. This consists of the CO₂ regulator and gauges, the connecting hoses and fittings, and the carbonator tank and subsequent water inlet check valves to prevent CO₂ backflow into the water supply system. To locate, use bubble soap to cover areas suspected and look for air bubbles. (The children's type bubble soap sold nationwide is excellent to use since it is FDA approved, economical, and leaves no residue). The water inlet check valves may be leaking internally back into the water system. If so, a foul taste is usually evident in the soda dispensed. The only way to verify a defective check valve is to take it off the unit and connect 100# of CO₂ to the "out" side and note any seepage back thru the valve indicating an opening.

NOTES

PARTS ILLUSTRATED
TABLE OF CONTENTS

ILLUSTRATION	PAGE
Cabinet Assembly.....	31
Light Fixture Assembly.....	38
Slanted Panel.....	35
Lock Assembly.....	36
Junction Box.....	33
Door Assembly.....	37
Power Deck Assembly.....	39
Evaporator Tank Assembly.....	41
Carbonator Assembly.....	43
Carbonator Tank Assembly.....	45
Carbonator Switch Assembly.....	47
Valve Assembly - Dole.....	49
Syrup Tank Asssembly.....	52
Valve Assembly - McCann.....	53
Regulator Assembly.....	55
Disconnect Socket Assembly.....	56
Alphabetical Parts List.....	57

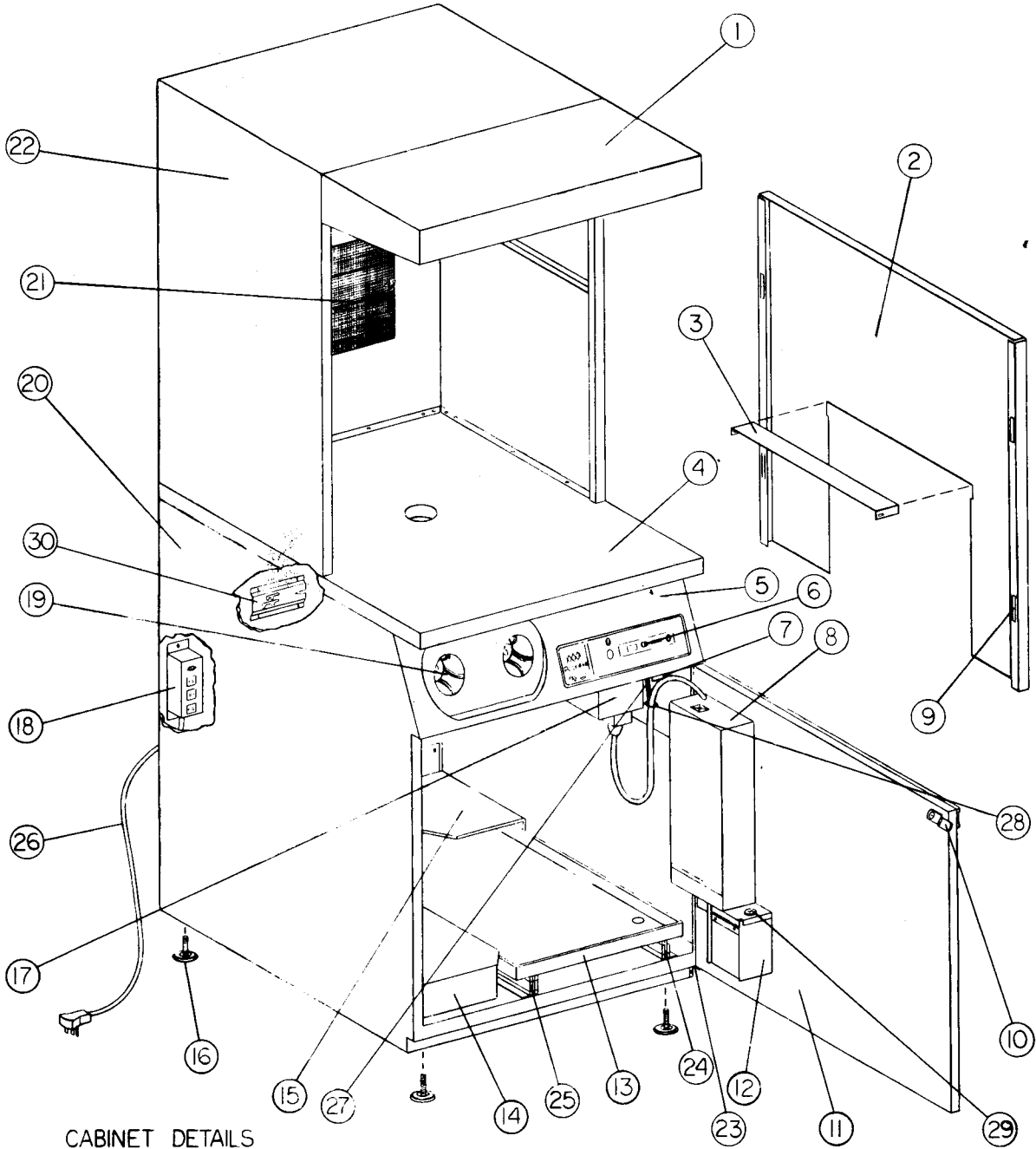

CABINET DETAILS

CABINET ASSEMBLY

ITEM	PART NO.	DESCRIPTION
1	D-11325	Light Fixture Assembly
2	C-11749-01	Cowling W/Out Magnetic catches
3	A-11747	Cowling Lip
4	D-11763	Countertop
5	D-11777	Slanted Panel Assembly
6	A-5322	Reject Lever Plunger
	B-5055-01	Reject Lever (not shown)
	A-5366	Pin Cap (not shown)
	A-610	Spring (not shown)
7	A-11023	Coin insert chute W.A.
8	as specified	Coin changer
9	A-5386	Magnetic catch
10	B-11117-*	Lock Assembly (Chicago)
	A-11377-*	Lock Assembly (National)
11	D-11153	Lower Door Assembly
12	A-11051-01	Coin Bank W.A. (No top)
	A-12519	Coin Bank W/Locktop (Less lock)
13	B-8559-01	Sliding tray
14	B-11748-01	Carbonator Bracket
15	B-5321	Corner Shelf
16	A-2601	Leg Glide
17	D-11753	Electrical Box Assembly
18	C-11139	Junction Box Assembly
19	A-5181	Cup Dispenser
20	C-11102-01	Lower Cabinet W.A.
21	C-8512	Upper Cabinet Screen
22	C-11041-01	Upper Cabinet W.A.
23	A-11020-01	Lower Hinge Bracket W.A.
24	C-8553-02	Slide Assembly
25	C-8553-01	Slide Assembly
26	B-5801	Service Cord
27	A-84	Spring
28	A-2369	Cable Clamp
29	B-11114-*	Lock Assembly Coin Box (Chicago)
	A-11382-*	Lock Assembly Coin Box (National)
30	A-11761	Mounting Bracket (Reg. Assembly)

* Specify Key Number

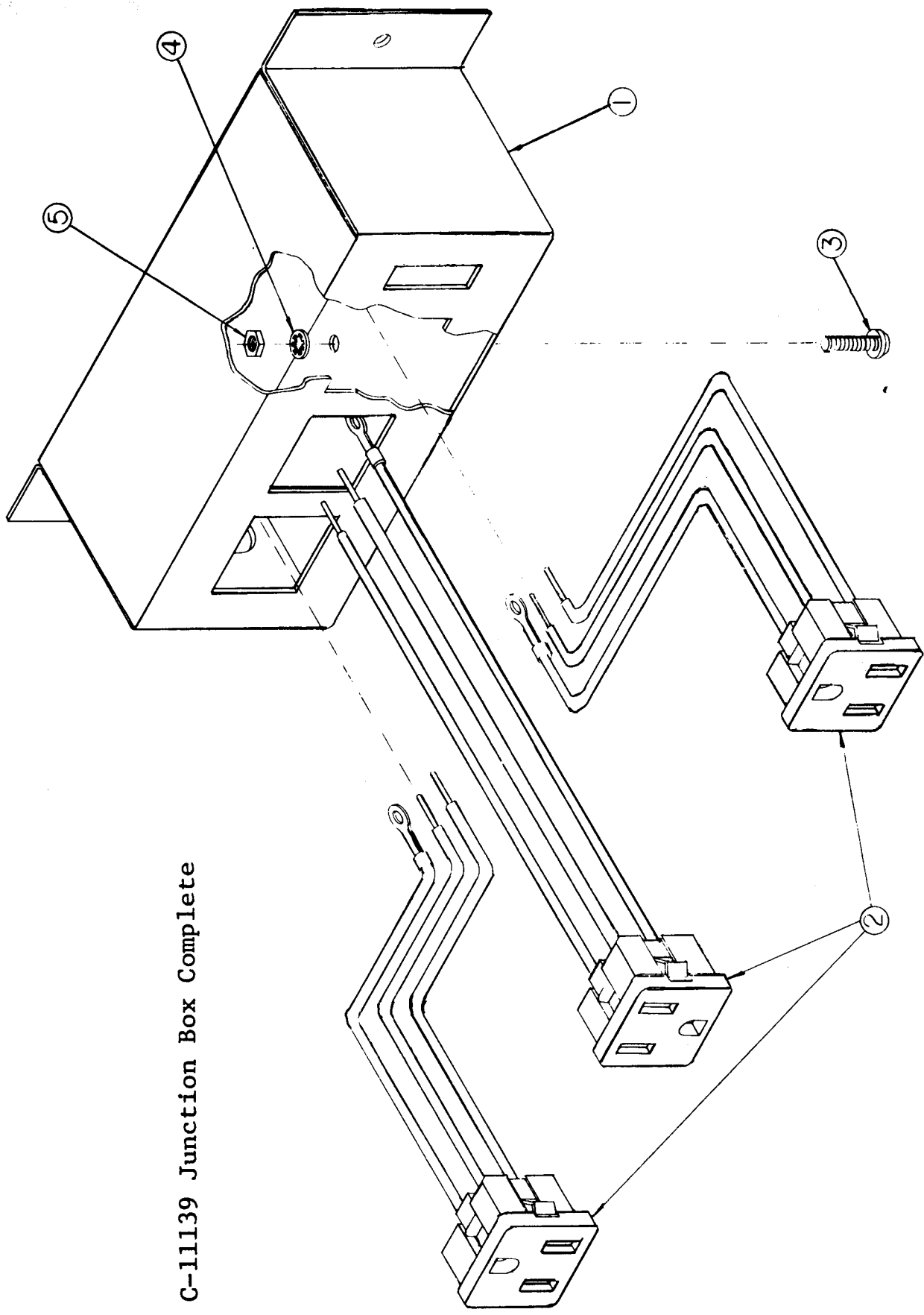

C-11139 Junction Box Complete

ITEM	PART NO.	QTY	DESCRIPTION
1	A-5296	1	BOX - JUNCTION
2	A-2421	3	OUTLET, 3 WIRE
3	A-5367	1	SCREW - MCH PAN #8-32 X 1/2
4	A-266	1	WASHER - INT TOOTH #8
5	A-195B	1	NUT - HEX #8-32 ZP

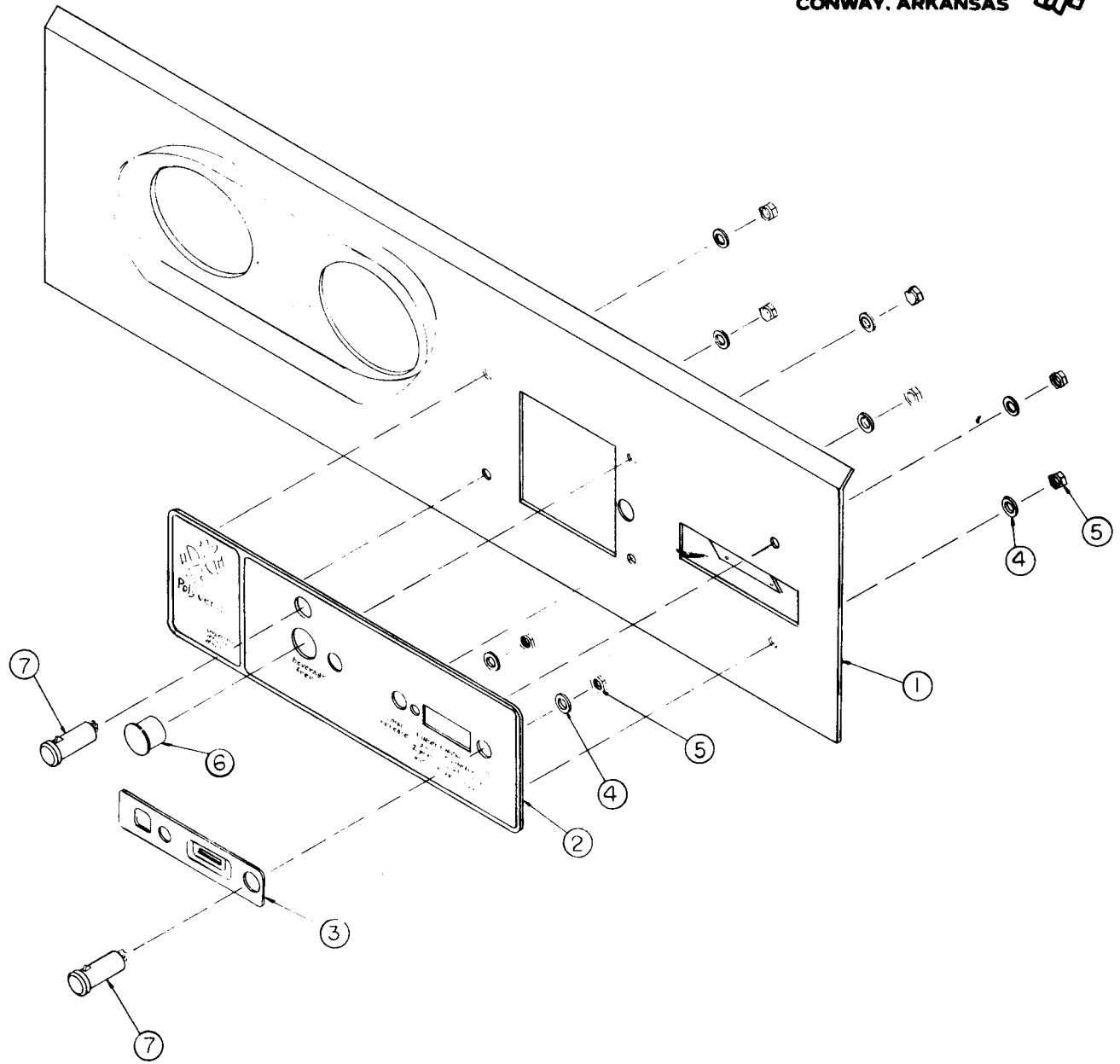

D-11777 Slanted Panel Assembly Complete

ITEM	PART NO.	QTY.	DESCRIPTION
1	C-11037-01	1	Panel - Assembly Slanted
2	B-11194	1	Plate - Assembly Overlay
3	A-11017	1	Insert - Trim Plate
4	A-5364	8	Washer - Flat
5	A-3030	8	Nut - Hex
6	A-5496	1	Plug - Domed
7	A-5083	2	Lamp - Indicator

ITEM	PART NO.	DESCRIPTION
1	A-11525-*	1½" Tumbler
2	A-11664	Barrell
3	A-5292	Escutcheon - Flat
4	A-355	Nut - Hex
5	A-5266	Cam - ½" offset (Lower door)
6	A-5293	Screw

(Chicago Lock)

* Please Specify Key No.

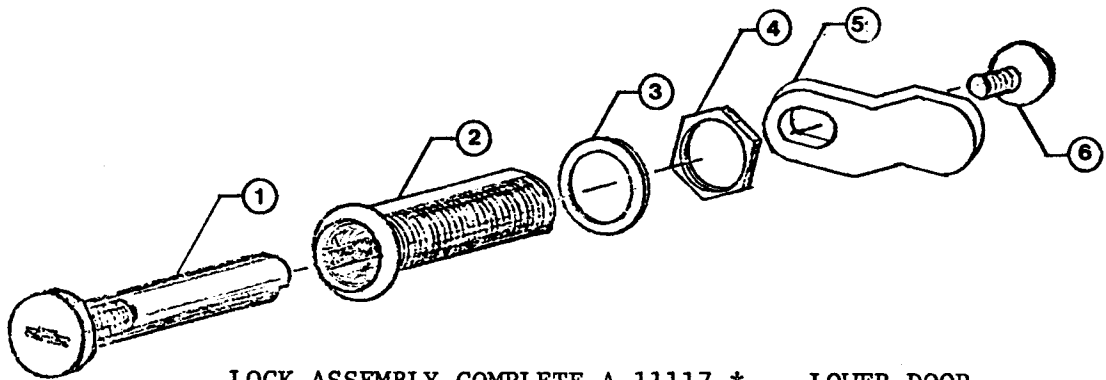

LOCK ASSEMBLY COMPLETE A-11117-* LOWER DOOR

ITEM	PART NO.	DESCRIPTION
1	A-11531-*	Lock Barrel & Tumbler
2	A-8504	Washer - Flat
3	A-11520	Nut - Hex
4	A-8495	Cam - Lock - Lower Door
5	A-11521	SEMS Unit

(National Lock)

* Please specify key No.

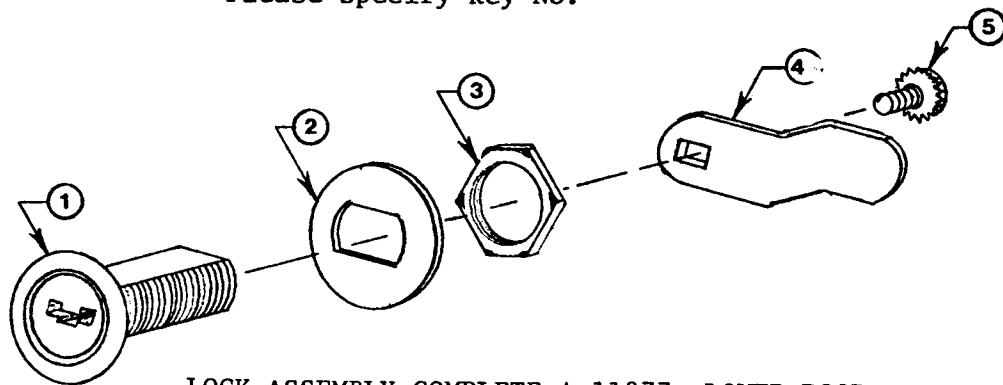

LOCK ASSEMBLY COMPLETE A-11377 LOWER DOOR

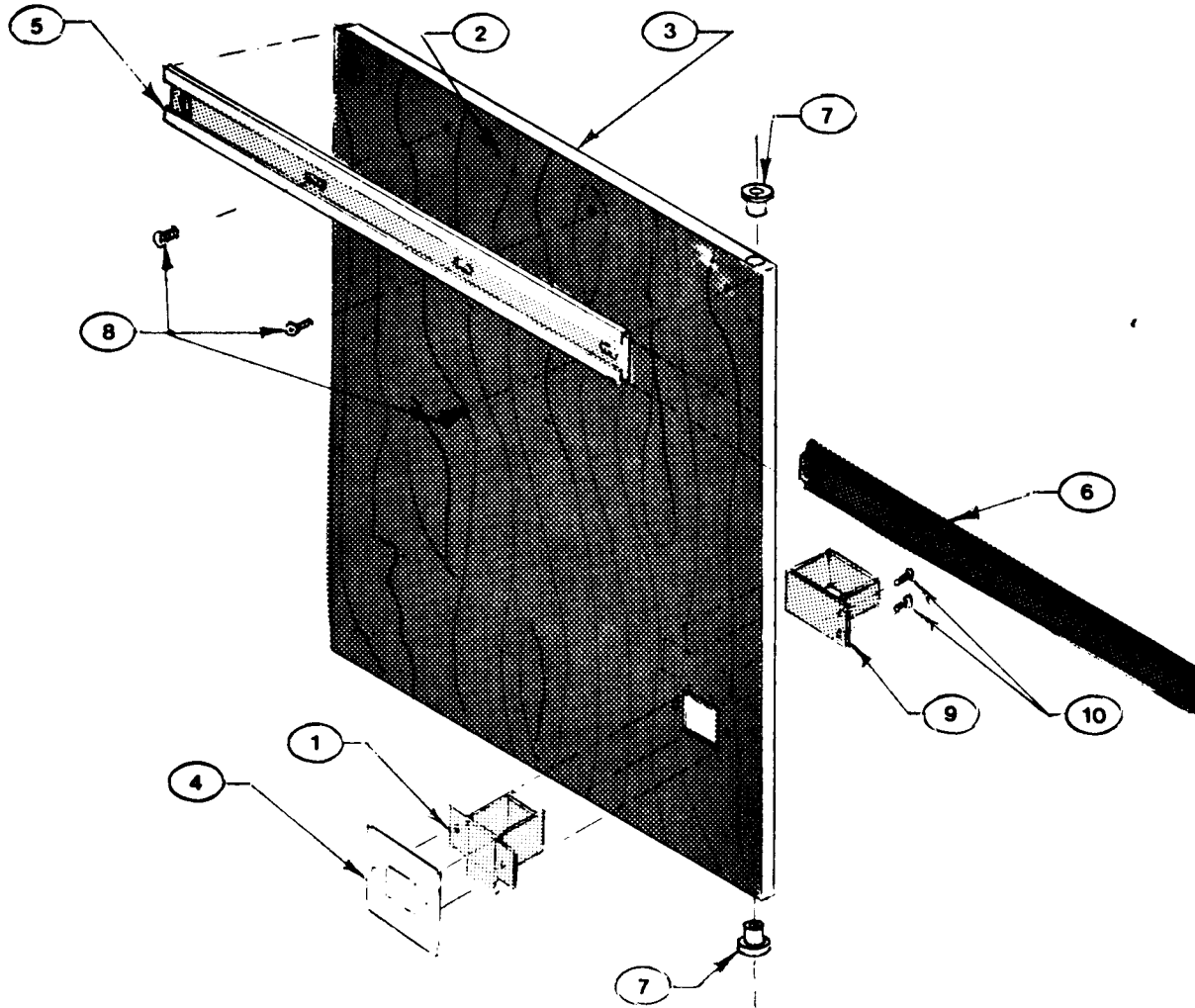

LOWER DOOR ASSEMBLY B11153

<u>FIGURE NO.</u>	<u>PART NO.</u>	<u>NAME</u>
1	A-10342	Coin Return Cup Assembly
2	B-5067	Outer Door Panel
3	C-11054	Inner Door Panel Assembly
4	B- 858-02	Trim Plate - Coin Return Cup
5	B-4615	Lower Trim
6	A-4623	Lower Trim Insert
7	A-5280	Hinge Bushing
8	A-1465	Screw #8-32 x 3/8 Machine
9	B-11049	Coin Hopper
10	A-1298	Screw #8 x 3/8 Type AB

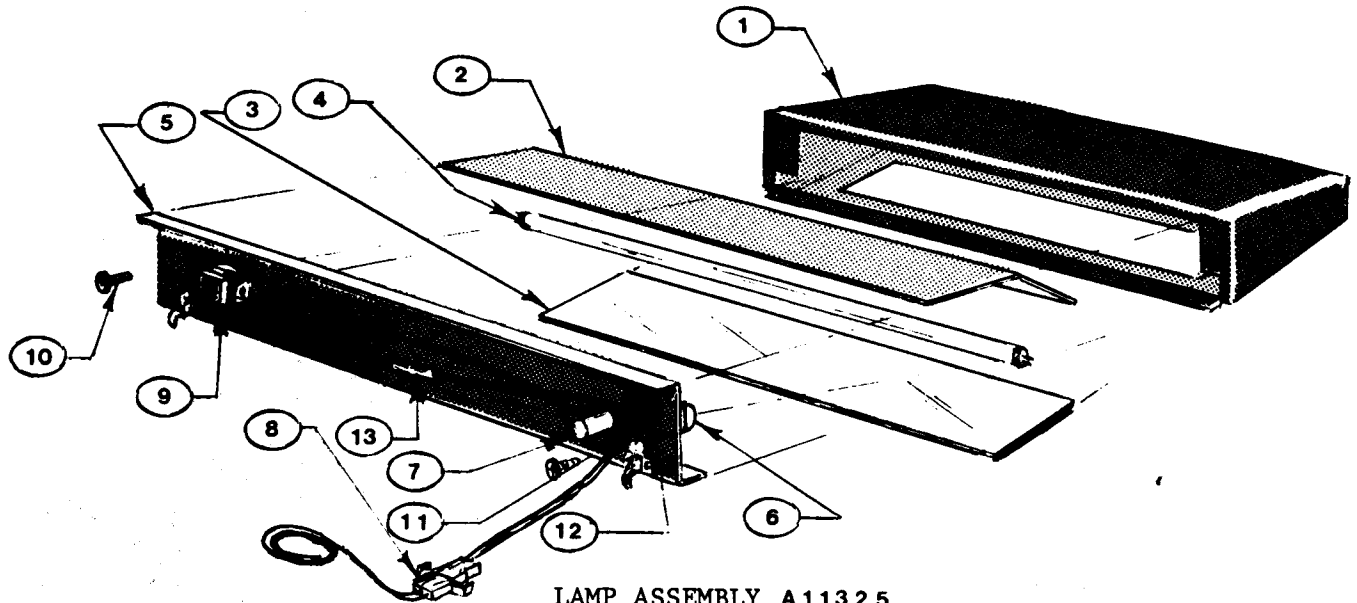

LAMP ASSEMBLY A11325

<u>FIGURE NO.</u>	<u>PART NO.</u>	<u>NAME</u>
1	C-11320	Light Fixture
2	B-5167	Light Deflector
3	B-5822	Light Diffuser
4	A-5373	Lamp F15T12CW 15 Watt
5	B-11324	Lamp Bracket Assembly
6	A-801	Lampholder AMP 1-480344-0
7	A-2607	Starter FS-25
8	A-4844	Plug -- Molex 1545P
9	A-104	Ballast GE89G457G5
10	A-1868	Screw #8 x 1/4 Type B
11	A-1466	Starter Socket Kulka 596
12	A-5378	Cable Clamp Richco E4(1/2)

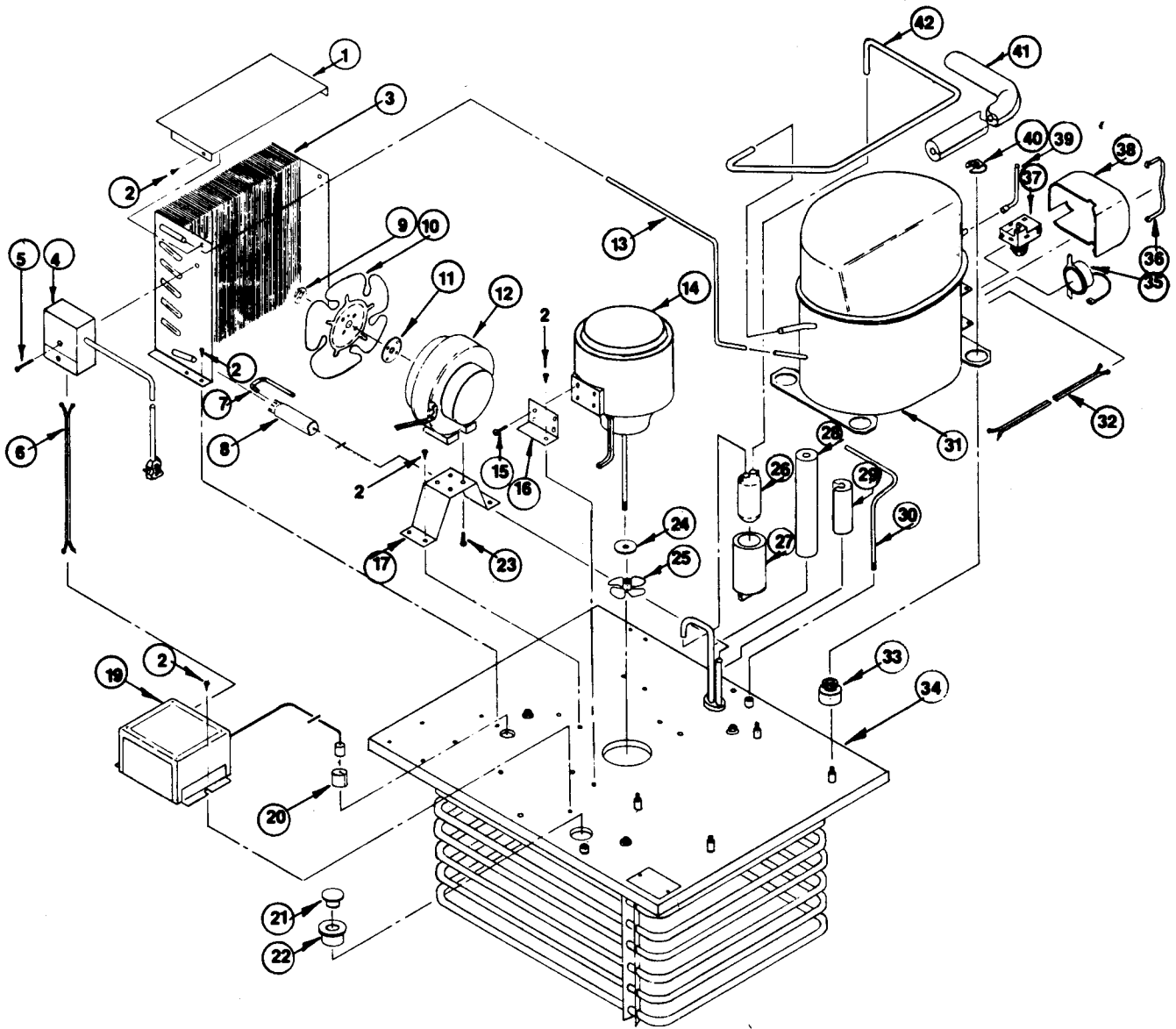

POWER DECK ASSEMBLY

INDEX	PART NO.	DESCRIPTION
1		Condensor Shield, Top
2		Screw
3		Condensor
4		Power Cord Assembly
5		Screw
6		Electric Cable
7		Tube
8		Dryer Cap Assembly
9	A-12065	Nut
10	A-12464	Fan
11		Silencer, G.E.
11a	12466	Silencer, Morrill
12	A-12463	Fan Motor
13		Tube
14	A-12462	Agitator Motor
15		Screw
16		Bracket
17		Bracket
18		Transformer Assembly
19	A-12467	Control, Ice Bank
20		Seal
21		Cover
22		Sleeve
23		Screw
24	A-12468	Washer
25	A-12469	Propeller
26		Accumulator
27		Boot
28		Insulation
29		Insulation
30		Handle
31		Compressor
32		Electric Cable
33		Grommet
34		Evaporator Assembly
35	A-12470	Overload Assembly
36		Bale Strap
37	A-12471	Relay
38		Terminal Cover
39		Tube
40		Clip
41		Insulation
42		Tube
	A-12461	Ref. Unit Assembly Complete

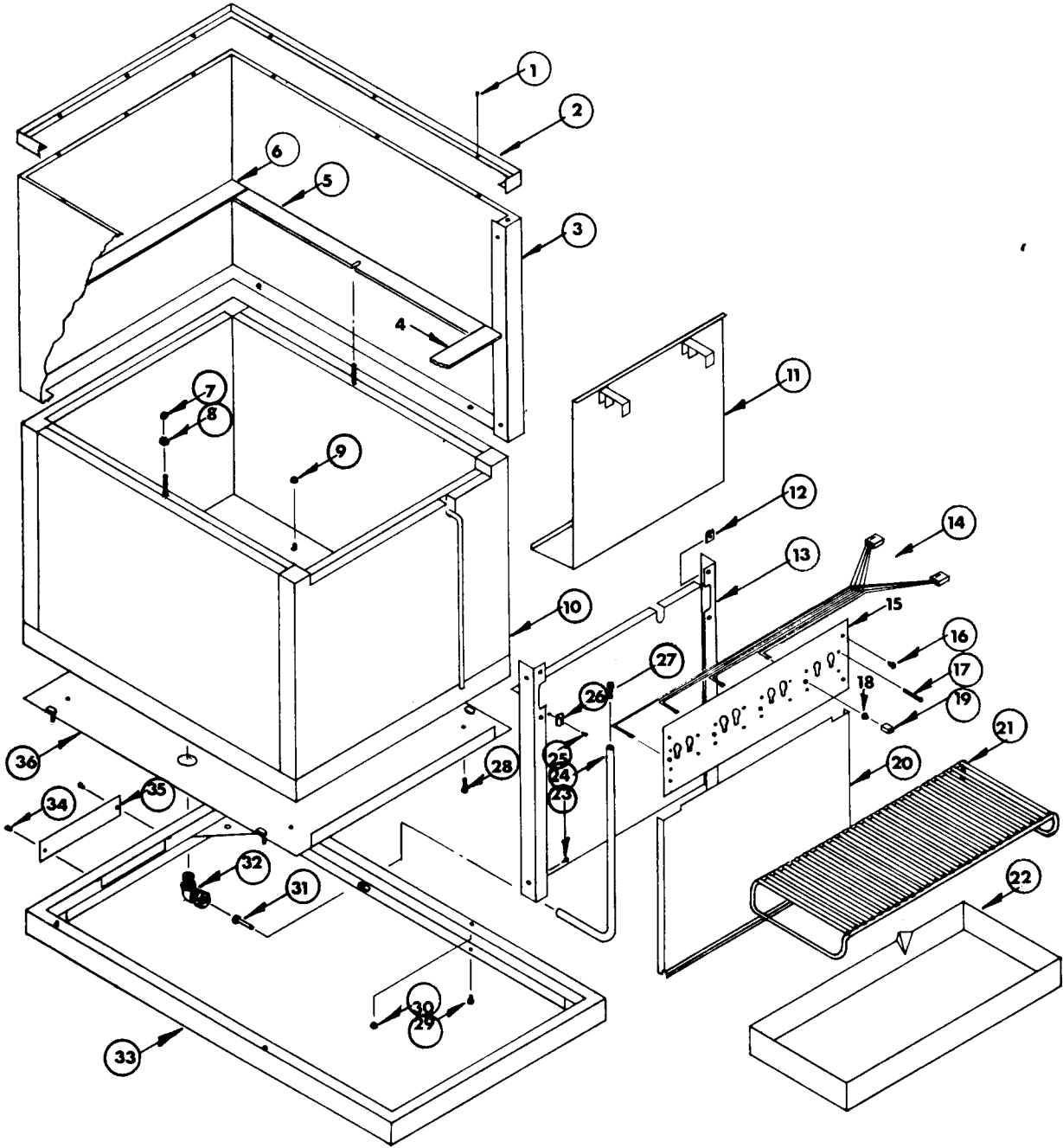

Evaporator Tank Assembly

INDEX	DESCRIPTION
1	Rivet
2	Trim
3	Exterior Wrap-Stainless
3a	Exterior Wrap-Wood Grain
4	Seal, Front
5	Seal, Right
5a	Seal, Left
6	Seal, Back
7	Nut
8	Washer
9	Nut
10	Tank Assembly
11	Insulator Plate Assembly
12	Nut
13	Front Plate Support
14	Wiring Harness - 3 Faucet
14a	Wiring Harness - 4 Faucet
15	Faucet Plate - s Faucet Elec.
15a	Faucet Plate - 4 Faucet Elec.
16	Screw
17	Screw (Dole Valve)
17a	Screw (McCann Valve)
18	Bushing
19	Socket Housing
20	Splash Plate - Refresh Unit
21	Cup Rest
22	Drip Tray Assy - Ref.
23	Screw
24	Tube
25	Screw
26	Clip
27	Drain Fitting
28	Screw
29	Slide
30	Nut
31	Tube Support
32	Elbow Fitting
33	Base Assembly
34	Screw
35	Cover Plate
36	Plate Assembly

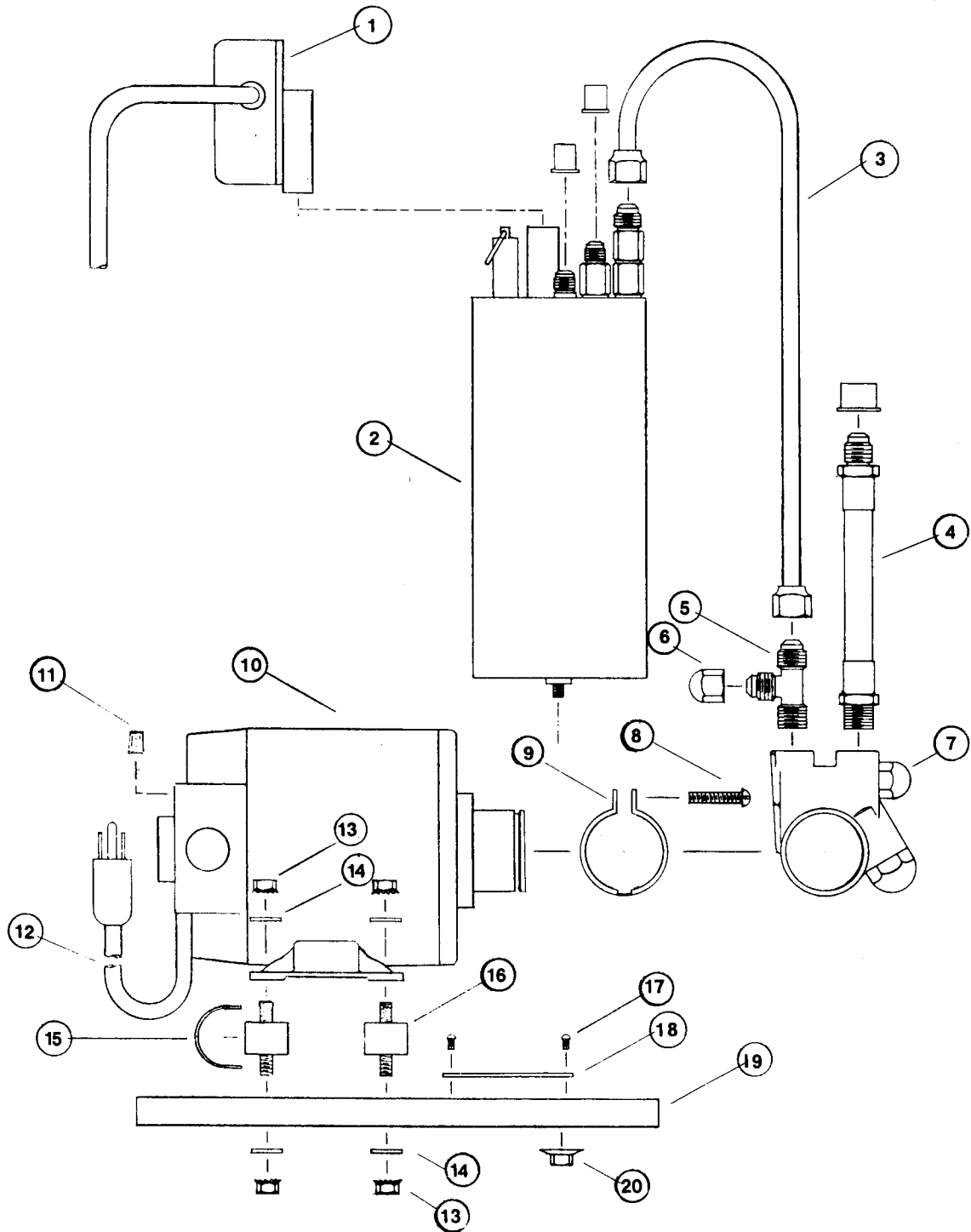

CARBONATOR ASSEMBLY

ITEM	PART NO.	DESCRIPTION
1	A-12472	Proximity Switch Assembly
2	A-12473	Carbonator Tank
3	A-12474	Tubing Assembly
4	A-12475	Tubing Assembly
5		Tee
6		Cap Nut
7	A-12476	Procon Pump with Strainer, 100 gph
7		Procon pump with Strainer, 70 gph
7		Procon pump-Stainless Steel, 45 gph
8		Screw
9	A-12477	Clamp with Screw
10	A-12478	Motor, 115V, 60 cy
11		Wire Nut
12		Power Cord Assembly for 115V
13		Lock Nut
14		Washer
15		Connector
16		Isolator
17		Screw
18		Name Plate
19		Base Plate
20		Lock Nut

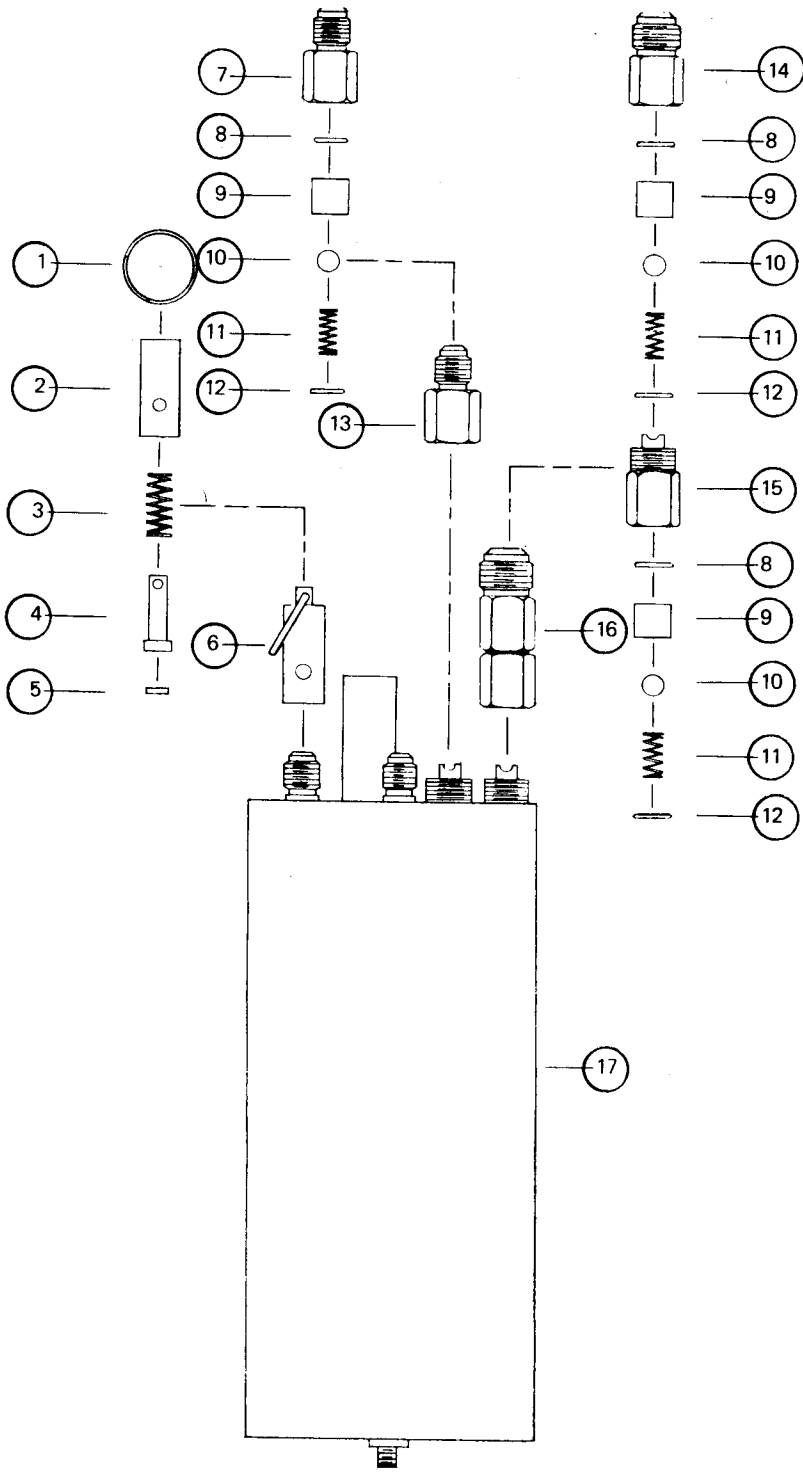

CARBONATOR TANK ASSEMBLY A-12473

ITEM	PART NO.	DESCRIPTION
1		Ring
2		Body
3		Spring
4		Stem
5		Seat
6		Relief Valve Assembly
7		Body
8		O-Ring
9		Sleeve
10		Ball
11		Spring
12		O-Ring
13	A-12479	Check Valve Assembly
14		Body
15		Body
16	A-12480	Check Valve Assembly
17		Tank

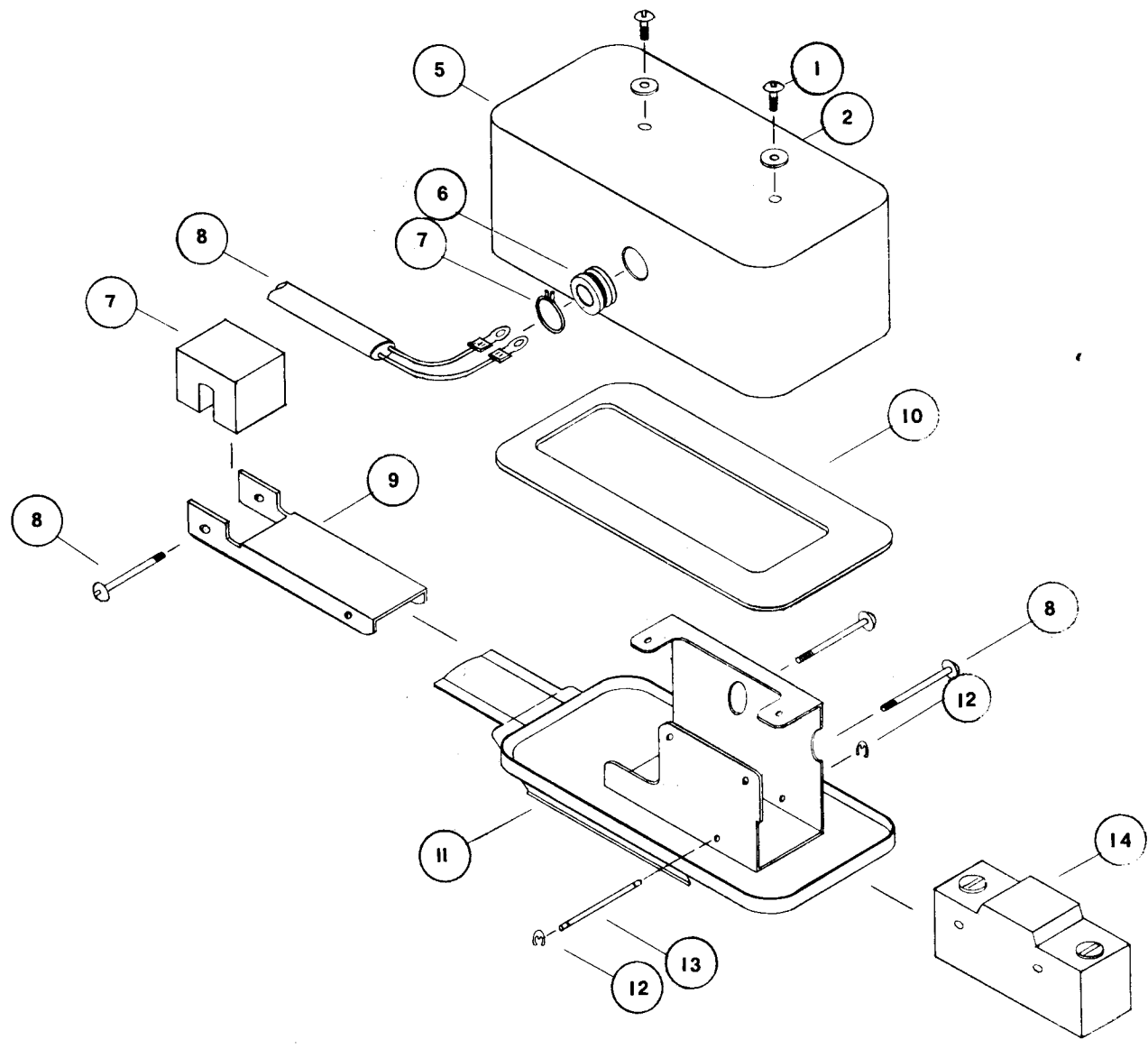

CARBONATOR SWITCH ASSEMBLY A-12472

ITEM	DESCRIPTION
1	Screw
2	Washer
3	Cover
4	Grommet
5	Retainer Clamp
6	Switch Cable
7	Magnet
8	Screw
9	Arm
10	Gasket
11	Base Assembly
12	Retaining Ring
13	Pin
14	Switch



Polyvend
CONWAY, ARKANSAS

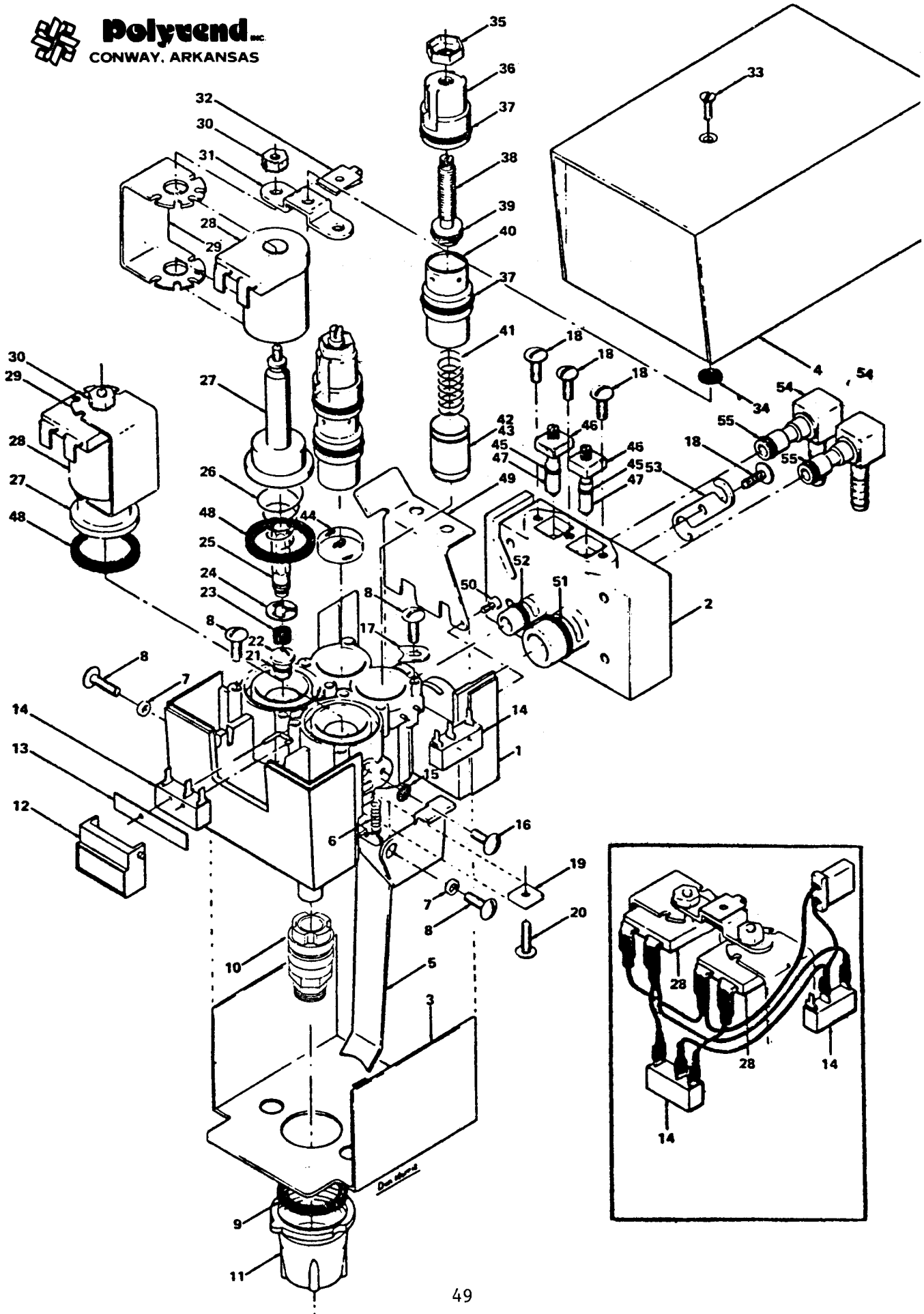

VALVE ASSEMBLY A-12740

ITEM	PART NO.	DESCRIPTION
1		Body
2	A-12790	Mounting Plate
3		Bottom Cover (old & new style)
4	A-12788	Top Cover Black (new style)
5		Lever
6		Spring
7		Bushing
8		Screw
9	A-12786	Seal
10	A-12789	Diffuser Assembly
11	A-12791	Nozzle
12		Button
13		Retainer Switch
14	A-12792	Switch
15	A-4388	O-Ring
16	A-12768	Screw
17		Hold Down Washer
18		Self Tapping Screw
19		Nozzle Retainer Nut
20		Nozzle Retaining Screw
21		Port - Syrup
22		Port - Water
23	A-12796	Seat
24		Retainer Ring
25		Armature
26		Spring
27		Guide Assembly
28		Coil
29		"C" Frame
30		Locknut
31		Retaining Strip
32		Speed Nut
33	A-12770	Screw
34		Fibre Washer
35		Locknut
36	14788	Retainer 3.57
37	A-12783	O-Ring
38		Valve Stem
39	A-8729	O-Ring
40-42	A-12793	Spool & Sleeve Ass'y-Syrup
43-40	A-12794	Spool & Sleeve Ass'y-Water
44		Screen (Water side only)
45	A-12784	O-Ring
46		Nut
47		Valve Stem Shut-Off
48		Tetraseal Gasket
49		Clamp
50	A-12769	Screw

ITEM	PART NO.	DESCRIPTION
51	A-12785	O-Ring
52	A-8709	O-Ring
53		Clip
54		Elbow
55	A-12429	O-Ring
**	A-12740	Complete Dole Valve, double switch
**	A-12795	Packet, Labels (new cover front and rear)
**	A-12797	Diffuser, Hicarbonation

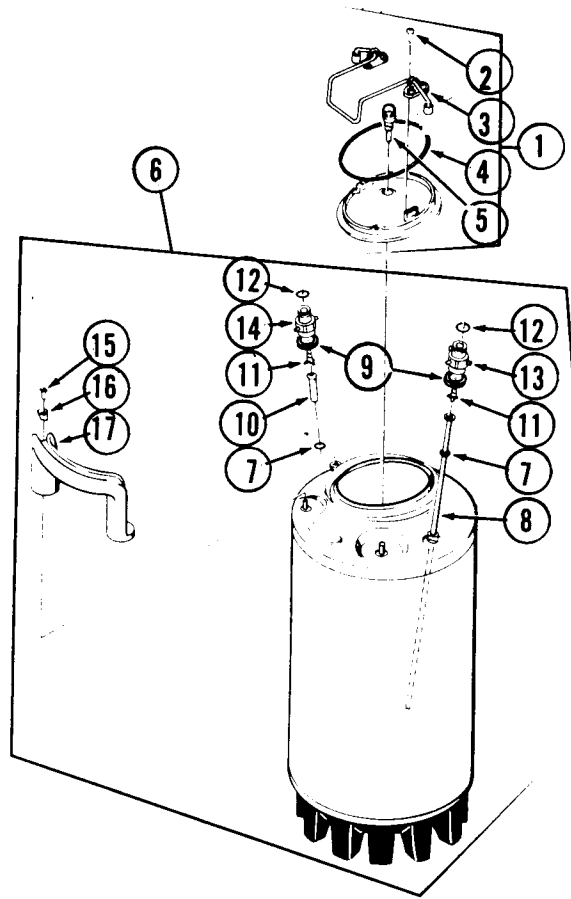

SYRUP TANK ASSEMBLY A-5335 & 5336

ITEM NO.	PART NO.	NAME
1	A-5336	Cover Assembly, Red (includes 2 thru 5)
2	A-8731	#10 x 1/2 Screw, SS Type B Phillips
3	A-8739	Cover Handle Kit
4	A-5476	"O" Ring (Cap)
5	A-5477	Relief Valve
6	A-5335	Tank Assembly (includes 7 thru 18)
7	A-8733	"O" Ring (Tank)
8	A-8478	Syphon Tube
9	A-8737	Washer, Stainless Steel
10	A-8736	Gas Tube
11	A-8734	Valve Poppet Assembly
12	A-5474	"O" Ring (Valve)
13	A-8568	Connector Body, Outlet (includes 12)
14	A-8569	Connector Body, Inlet (includes 12)
15	A-8732	1/4-20 x 3/8 Screw, self locking Stainless
16	A-8730	Washer, Handle
17	A-5475	Handle, Tank-Black

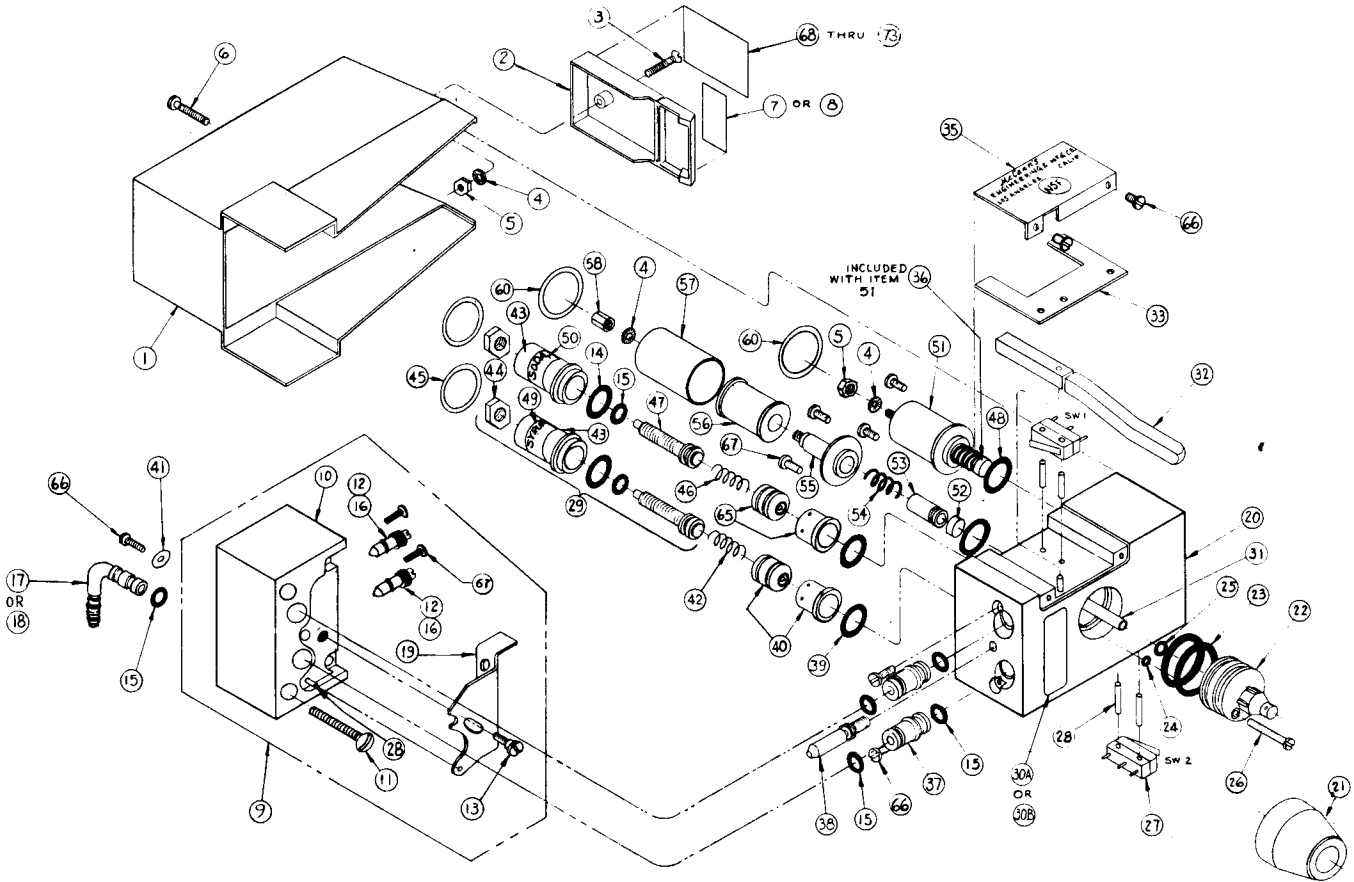

12432 Valve Assy Complete-McCann

ITEM	PART NO.	DESCRIPTION	ITEM	PART NO.	DESCRIPTION
1	A-12433	Cover top, plastic	17		Inlet fitting 90° for 26 series
2	A-12434	Medallion, Plastic wht.	18		Inlet fitting, straight for 26 series
3	A-12435	Screw 6-32, Medallion	19		Locking brkt., back block
4		#6 Lockwasher Medallion	20		Base block asy with roll pins & syrup tube
5	A-4203	Nut Hex 6-32 Medallion S.S.	21	A-12438	Spout
6	A-12430	Screw 8-32 Pan Captive	22	A-12439	Diffuser
7		Decal "Soda"	23	A-12440	"O" Ring, Diffuser large
8		Decal "Water"	24	A-12441	"O" Ring, Diffuser screw
9		Back Block Assembly	25	A-12442	"O" Ring, Diffuser tube
10		Back Block	26	A-12443	Screw 4-40, Diffuser
11		Screw, 10-32 x 1½	27	A-12444	Micro-Switch
12		Back Block	28		Roll pin
13		"O" Ring, Back Block	29	A-12460	Flow control asy incl. items 14, 15, 43, 44 & 47
14	A-12437	"O" Ring, Control			
15	A-12429	"O" Ring			
16		Stem, Back Block			

ITEM	PART NO.	DESCRIPTION
30a		Label for 26-1006,2006
30b		Label for 26-1106
31		Tube, Syrup
32	A-12445	Lever, Actuating
33		Gasket, Rubber
34		Connector Assembly, Single Switch
35	A-12448	Plate, Side Cover Assembly
36		Plunger Assembly Included with Item 51
37		Fitting, Coupler
38		Pin, Guide
39		"O" Ring, Cylinder
40		Piston & Cylinder asy, syrup flow control
41		Washer Plain, Fitting
42		Spring, Syrup control
43		Housing, Flow control
44		Lock Nut, Flow control
45		Washer, Retainer Flow control
46		Spring, Soda Control
47		Screw Adjustment, Flow Control
48	A-12449	"O" Ring, Solenoid
49		Label Syrup, Flow Control
50		Label Soda, Flow Control
51	A-12450	Solenoid Assembly
52	A-12451	Rubber Tip, Diet & General
53		Plunger
54		Spring, Plunger
55	A-12453	Body Assembly, Plunger housing
56	A-12454	Coil Assembly, Only
57		Housing Assembly, Solenoid
58		Stud, Mounting
59		Wire Assembly, Single Switch
60		Washer, Retainer Solenoid
61		Wire Assembly, 2 Switch
62		Wire Assembly, 2 Switch
63		Connector Assembly, 2 Switch
64		Connector Assembly
65		Piston and Cylinder Assembly, Soda Flow Control
66	A-12447	Screw 6-32
67		Screw 8-32 x 1/4, Solenoid Retainer
68		Coca-Cola Decal
69		Sprite Decal
70		Tab Decal
71		Fanta Root Beer Decal
72		Fanta Orange Decal
73		Fanta Grape Decal
*	A-12627	Tube-Diverter, Brixing

* Not shown



Regulator Ass'y

Regulator Repair Kit A12486
Includes Items 1,2,5,8,9,10

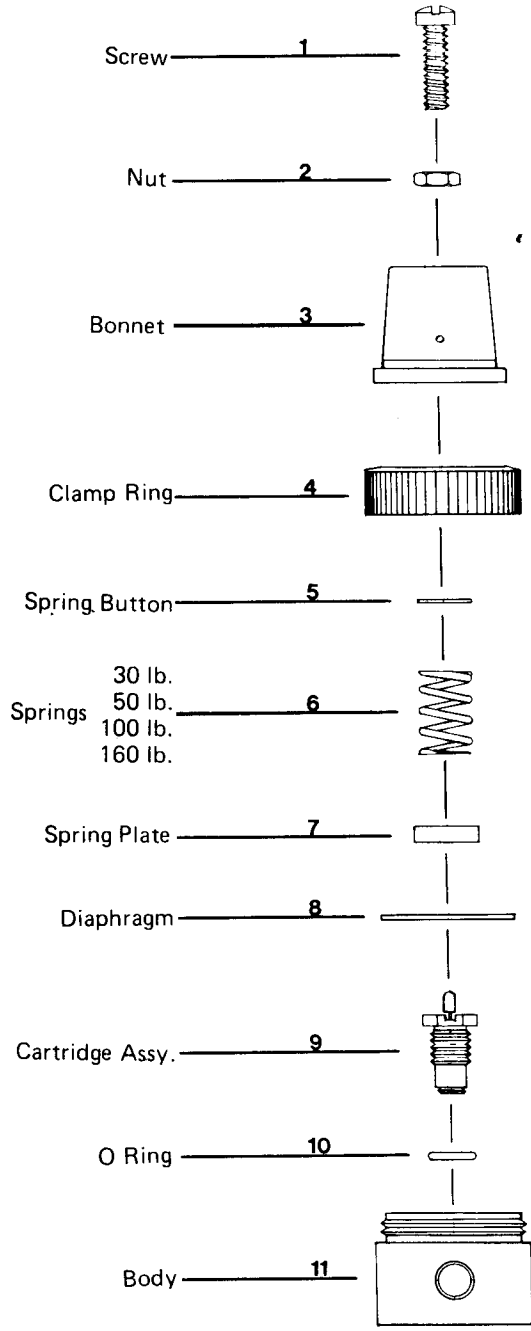



DISCONNECT SOCKETS A-12487 & A-12488

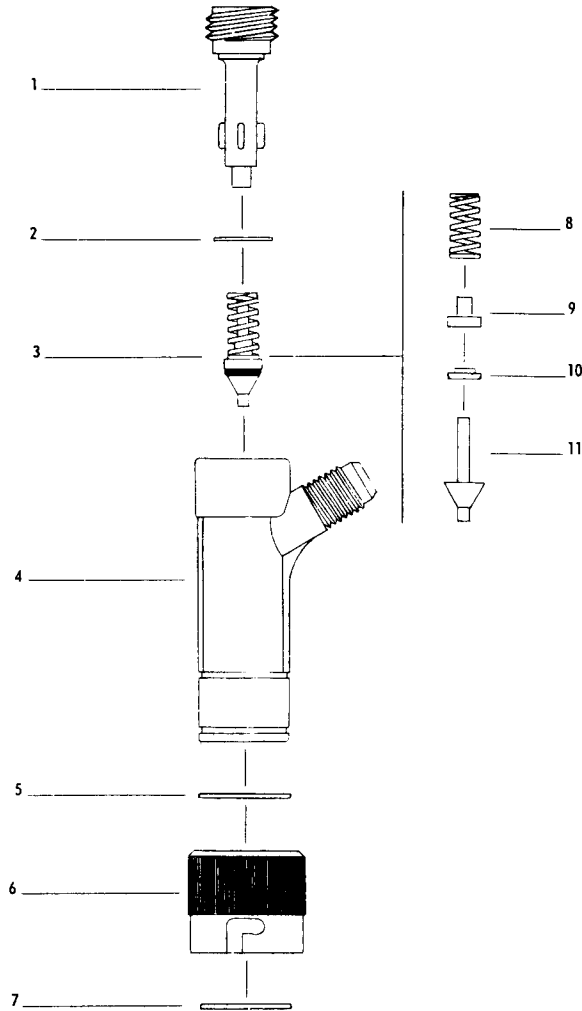

ITEM	DESCRIPTION
1	End Plug, Grey (gas) End Plug, Blk (liquid)
2	End Plug Seal Washer
3	Socket Valve Asy, Complete
4	Body (Stainless Steel Thread) 7/16"-20- Postmix
5	Lock Ring
6	Lock Collar (Gas; two slot) Lock Collar (liq. 3 slot)
7	Lock Ring
8	Valve Stem Spring
9	Washer Retainer
10	Valve Washer
11	Valve Stem

ALPHABETICAL PARTS LIST

CSV-4

3300 SERIES

PART NO.	DESCRIPTION
A-11249-*	Bank-Coin - Complete with lock
A-12519	Bank-Coin - W/Lock Top (Less lock) (Optional)
A-11051-01	Bank-Coin - W.A. (No top)
A-11664	Barrell-Lock, Chicago
A-11531	Barrell and Tumbler - National (Specify key NO.)
A-12431	Board-Circuit, Control Box
A-12453	Body Asy- Plunger Housing, McCann Valve
A-11759	Bolt-Hex Head, Dispenser/Countertop
A-5296	Box - Junction
A-11139	Box - Junction Asy. - Complete
D-11324	Bracket Asy - Lamp (includes ballast, starter, socket and harness)
B-11784-01	Bracket - Carbonator, Cabinet
A-11020-01	Bracket - Lower Hinge WA
A-11761	Bracket - Mounting, Wall (Reg. Asy.)
B-11048-01	Bracket - Rear Dup Dispenser WA
A-1653	Bumper-Pressure Sensitive, Lower Cabinet/Door
A-5280	Bushing-Door Hinge
A-1961	Bushing-Snap 1½"
A-2358	Bushing-Nylet
A-5803	Bushing-Snap, Jct Box 7/16 I.D.
A-5802	Bushing-(Strain Relief) - Service Cord
C-11102-01	Cabinet- W.A. - Lower
C-11041-01	Cabinet- W.A. - Upper
A-5266	Cam- ½" Offset (Lower Door) Chicago
A-8501	Cam-Lock, Coin Bank
A-8495	Cam-Lock, (Lower Door) National
A-5366	Cap - Pin, Reject Lever
A-11755	Carbonator Kit - Complete
*	Carbonator - See "Tank" "Motor" etc.
A-2372	Catch-Elbow, Light Fixture
A-5386	Catch-Magnetic - Cowling
A-5388	Chain-Sash, CO ₂ Tank
A-2369	Clamp-Cable, Coin Changer
A-12477	Clamp-W/Screw, Pump/Motor
A-12454	Coil-McCann Valve
A-11023	Coin Insert Chute W.A.
*	Coin Changer - (As specified)
*	Coin Bank - See "Bank"
A-8569	Connector Body - Syrup Tank, Inlet
A-8568	Connector Body - Syrup Tank, Outlet
A-111	Connector-Splice Cap, Jct Box/Service Cord

PART NO.	DESCRIPTION
D-11753.....	Control Box Asy Complete
A-12460.....	Control Asy-Flow, McCann Valve
A-12467.....	Control - Ice Bank
B-5801.....	Cord-Service
D-11763.....	Countertop W/Holes
A-5336.....	Cover Asy-Syrup Tank Complete
A-12788.....	Cover-Top, Black Dole Valve
A-12433.....	Cover-Top, Black McCann Valve
C-11749-01.....	Cowling-W/O Magnetic Catches
C-11760.....	Cowling Asy.-W/Magnets
A-10342.....	Cup Asy - Coin Return
*.....	Cup Dispenser See "Dispenser"
*.....	Data Plate - See "Plate"
A-11756.....	Decal-Kit, Valves, Flavors
A-5391-01.....	Decal- Price - 10¢
A-5391-02.....	Decal- Price - 15¢
A-5391-03.....	Decal- Price - 20¢
A-11540.....	Decal, Warning, 115 Volts
A-5077.....	Deflector-Coin, Lower Door
B-5167.....	Deflector-Light, Lamp Asy
A-12789.....	Diffuser Asy - Dole Valve
A-12797.....	Diffuser- Hicarbonation, Dole Valve
B-5828.....	Diffuser-Light
A-12439.....	Diffuser-McCann Valve
A-5181.....	Dispenser-Cup - Complete
A-11781-01.....	Dispenser-Post Mix Complete W/Dole Valves-Std.
A-11781.....	Dispenser-Post Mix Complete W/McCann Valves- Opt.
A-11754.....	Dispenser-Post Mix Complete - 3 Selection
*	Diverter Tube- See "Tube"
D-11153.....	Door Asy. - Lower Complete
C-11054-01.....	Door W.A. - Lower
A-5292.....	Escutcheon - Flat, Chicago Lock
A-12464.....	Fan, Condensor
A-5874.....	Filter, Water, Cold (Cartridge)
A-11160.....	Filter, Kit- Water, Complete
A-11325.....	Fixture-Asy Complete, Light
C-11320-01.....	Fixture-WA, Light
*.....	Flow Control- See "Control"
**.....	Fuse-3/4 AMP- Control Box, M.D.L. 250V
A-12484.....	Gauge-Lens (For A-12481, 12482, 12483)Glass
A-12481.....	Gauge-Pressure 0-100
A-12482.....	Gauge-Pressure 0-160
A-12483.....	Gauge-Pressure 0-2000
A-2601.....	Glide-Leg
A-8739.....	Handle Kit- Tank Lid
A-5475.....	Handle-Syrup Tank, Black
A-8582.....	Harness-Wiring, Light Fixture
*.....	Hinge - See "Bracket"

PART NO.	DESCRIPTION
B-11049-01.....	Hopper-Coin, Lower Door
*.....	Hose - See "Tubing"
A-4623.....	Insert-Lower Trim, Lower Door
A-11017.....	Insert-Trim Plate
A-112.....	Insulator-Splice Cap, Jct Box
*.....	Junction Box - See "Box"
A-12423.....	Kit-Cup Tube Cover (shipped with each machine)
A-12023.....	Kit-Floor Seal, NAMA approved (shipped with each machine)
*.....	Kit-See "Tank", "Regulator", "Filter", etc.
A-12795.....	Labels-Packet, Dole Valve
A-5373.....	Lamp-F15T12/CW, Overhead
A-5083.....	Lamp-Indicator, Overlay plate
A-12445.....	Lever-Actuating, McCann Valve
B-5055-01.....	Lever-Reject
A-2601.....	Leg Glide
A-11117-*.....	Lock Asy- Chicago, Complete (specify key No.) Door
A-11377-*.....	Lock Asy- National, Complete(specify key No.) Door
B-11114-*.....	Lock Asy- (Coin Bank) Chicago,(specify key No.)
A-11382-*.....	Lock Asy-Coin Bank (National) (specify key no.)
*.....	Lock-See "Barrell", "Tumbler", etc.
*.....	Lockwasher- See "Washer"
*.....	Lid-Tank See "Cover"
*.....	Light- See "Lamp" or "Fixture"
A-11747.....	Lip-Cowling
A-5386.....	Magnetic Catch - Cowling
A-12434.....	Medallion-Plastic, White, McCann Valve
A-12462.....	Motor, Agitator
A-12463.....	Motor, Fan
A-12478.....	Motor- Procon Pump
A-12791.....	Nozzle-Dole Valve
A-12438.....	Nozzle-McCann Valve
A-12065.....	Nut, Condensor Fan
A-4203.....	Nut-Hex #6-32, Medallion, S.S.- McCann Valve
A-1958.....	Nut-Hex, #8-32 "ZP", Jct Box
A-3030.....	Nut-Hex, Overlay Plate
A-355.....	Nut-Hex, Chicago Lock
A-11520.....	Nut-Hex, National Lock, Door and Coin Bank
A-2385.....	Nut-Hex, 1/4-20, Carb. Bracket
A-12784.....	O-Ring-Dole Valve, Shut Off Screw AS-006
A-4388.....	O-Ring-Dole Valve, Lever Screw AS-008
A-12429.....	O-Ring-Dole Valve, Elbow AS-010
A-8709.....	O-Ring-Dole Valve, Back Block,Water AS-011
A-8729.....	O-Ring-Dole Valve, Adj. Screw AS-012
A-12785.....	O-Ring-Dole Valve, Back Block, Syrup AS-015
A-12783.....	O-Ring-Dole Valve, Syrup/Water AS-017
A-12437.....	O-Ring-McCann Valve, Control Housing

PART NO.	DESCRIPTION
A-12440.....	O-Ring-McCann Valve, Diffuser
A-12441.....	O-Ring-McCann Valve, Diffuser Screw
A-12442.....	O-Ring-McCann Valve, Diffuser Tube
A-12449.....	O-Ring-McCann Valve, Solenoid
A-12429.....	O-Ring-McCann Valve, Stem, Back Block AS-010
A-8733.....	O-Ring-Syrup Tank Tube
A-5474.....	O-Ring- Syrup Tank
A-5476.....	O-Ring- Tank Lid
A-2421.....	Outlet - 3 Wire, Jct. Box
A-12470.....	Overload Asy - Compressor
B-5067.....	Panel-Outer Door
C-11037-01.....	Panel-Slanted
D-11777.....	Panel-Slanted Asy Complete
A-5366.....	Pin Cap - Reject Lever
B-858-02.....	Plate-Coin Cup Trim
A-1293-29.....	Plate-Data
A-12790.....	Plate-Mounting, Dole Valve
B-11194.....	Plate-Overlay Asy
A-1302.....	Plate-Patent Notice
A-12448.....	Plate-Side Cover Asy., McCann Valve
A-5496.....	Plug-Domed, Slt. Panel
A-11990.....	Plug-Domed 3/8"
A-5375.....	Plug-Parallel Blade, Light Cord
*.....	Plunger-See "Tip", "Body", "Seal",etc..
A-5322.....	Plunger-Reject Lever
*.....	Pop Rivet - See "Rivet"
*.....	Price Decal - See "Decal"
A-12469.....	Propeller, Agitator Motor
A-12476.....	Pump-Procon with Strainer 100 gph
A-12461.....	Refrigeration Unit Asy complete
A-11757.....	Regulator Asy- High Pressure
A-11780.....	Regulator Asy- Low Pressure
A-11751.....	Regulator Asy - Low Pressure (3 selection machine)
A-12486.....	Regulator Repair Kit
A-12471.....	Relay- Compressor
A-859.....	Rivet-Drive, .125D x .250, Lower Door
A-729.....	Rivet-Pop .125 x .232, Lower Door, Light Fixture, Coin Chute, Reject Lever, Coin Bank Top,
A-4948.....	Rivet-Pop, Sliding Tray
A-12443.....	Screw- #4-40, McCann Valve Diffuser
A-12435.....	Screw- #6-32, Medallion, McCann Valve
A-12769.....	Screw- #6-32 x 3/16, Dole Valve, Clamp
A-12770.....	Screw- #6-32 x ¼, Dole Valve Cover
A-12447.....	Screw- #6-32, McCann Valve, Coupler Fitting
A-1715.....	Screw- #8 x 3/8, TP 23 Sems, Reg. Brkt.Mounting, Light Fixture, Control Box, Jct Box, Grd Wire serv. Cord
A-12768.....	Screw- #8 -18 x 7/16 Ty. "BT" S.S. Dole Valve

PART NO.	DESCRIPTION
A-1868.....	Screw-#8 x 1/4 TP "B", Cup dispenser, rear screen, Cowling lip
A-1298.....	Screw-#8 x 3/8 PH. TP "AB", Lower Door, Slide Asy
A-11894.....	Screw-#8 x 3/8 PH TP "23", Lower Door
A-2614.....	Screw-#8 x 1/2 Type "A", Lower Hinge Door
A-12430.....	Screw-#8-32 Pan Hd., Cover, McCann Valve
A-5367.....	Screw-#8-32 x 1/2 Mach., Junction Box
A-2574.....	Screw-#8 TP "AB" Trs., Ground Wire, Harness clamp
A-1299.....	Screw-#8 x 5/8" Ph. Pan Hd.- Upper Screen
A-8731.....	Screw-#10 x 1/2 S.S. Type "B" Ph. Lid Hdl.
A-8732.....	Screw- 1/4-20 x 3/8 S.S., Tank hdl.
A-5361.....	Screw-1/4-20 x 1/2 Steel, Pan Hd., Carb. Bracket
A-11521.....	Screw-Sems Unit, National Lock Door & Coin Bank
A-5293.....	Screw-Washer Head, Chicago Lock
A-9075-03.....	Screen-Rear Metal, 12 1/4 x 4 7/8
C-8512.....	Screen-Upper Cabinet
A-766-04.....	Screen-Fiberglass, 12 1/4 x 5 7/8"
A-12786.....	Seal-Nozzle/Valve, Dole
A-12796.....	Seat-Dole Valve, Diet & Sugar
B-5801.....	Service Cord
*.....	Slanted Panel - See "Panel"
B-5321.....	Shelf- Corner
A-11159.....	Shelf-Corner, Complete W/Screws
A-12466.....	Silencer, Condensor Fan
A-12414.....	Sleeve-Isolation, Countertop
A-12413.....	Sleeve-Isolation, Countertop
A-12550.....	Sleeve-Isolation, Countertop
C-8553-01.....	Slide Asy R.H.
C-8553-02.....	Slide Asy L.H.
A-12487.....	Socket-Disconnect- Tank Lines
A-12488.....	Socket-Disconnect-Tank Lines
A-12450.....	Solenoid Asy- McCann Valve
*.....	Splice Cap Connector, See "Connector"
*.....	Splice Cap Insulator, See "Insulator"
A-12793.....	Spool & Sleeve Asy- Dole Valve, Syrup
A-12794.....	Spool & Sleeve Asy- Dole Valve, Water
A-12438.....	Spout-McCann Valve
A-84.....	Spring-Coin Changer Cord
A-610.....	Spring-Reject Lever
A-2607.....	Starter-Light, FS-25
*.....	Strain Relief- See "Bushing"
A-810-07.....	Stripping-Neoprene, Lamp/Door
A-12792.....	Switch- Dole Valve
A-12444.....	Switch - McCann Valve
A-12472.....	Switch - Proximity Asy Complete
*.....	Syrup Tank - See "Tank"
A-12473.....	Tank Asy- Carbonator
A-5335.....	Tank Asy - Syrup Complete W/O Cover

PART NO.	DESCRIPTION
A-11778.....	Tank-Kit, 4 syrup, complete W/Covers
A-11136.....	Tank-Kit, 3 syrup, complete W/Covers
A-12451.....	Tip-Plunger, McCann Valve- Diet and Sugar
A-11250-01.....	Top W.A.- Coin Bank
B-8559-01.....	Tray - Sliding W/O Slide
**.....	Transformer, Control Box - Basler #13347-001
B-4615.....	Trim - Lower Door
A-12859.....	Tube - Diverter, Dole Valve
A-12627.....	Tube - Diverter, Brixing - McCann
A-8736.....	Tube - Gas, Syrup Tank
A-8478.....	Tube - Syphon, Syrup Tank
A-12474.....	Tubing Asy - Carb. Tank/Pump
A-12489.....	Tubing Asy - Gas 57" W/Connector and Swivel <i>to tank</i>
A-12490.....	Tubing Asy - Liquid 57" W/Connector and Swivel <i>to head</i>
A-12475.....	Tubing Asy - Inlet Water/Carb. Pump
A-12491.....	Tubing Asy - 30" Gas W/Swivels <i>CO₂ to carb</i>
A-12492.....	Tubing Asy - 38" Soda W/Swivels <i>carb to head</i>
A-11525-*	Tumbler- Chicago Lock (specify key No.)
A-11529-*	Tumbler-Lock Barrel, Coin Bank Top (specify key No.)
A-12479.....	Valve Asy - Check, Water Inlet (Single)
A-12480.....	Valve Asy - Check, Water Outlet (Dual)
A-12485.....	Valve - Check and Relief
A-12740.....	Valve - Dole, Double Switch Complete
A-11752.....	Valve - Check, Reg. Asy
A-12432.....	Valve - McCann Complete
A-8734.....	Valve - Poppet Asy. - Syrup Tank
A-5477.....	Valve - Relief, Tank Lid
A-12468.....	Washer - Agitator Fan Shaft
A-266.....	Washer - #8 Int. Tooth, Jct. Box, Ground Wire
A-8504.....	Washer - Flat, National Lock, Door, Coin Bank
A-5364.....	Washer- Flat, Overlay Plate
A-11750.....	Washer-Flat, Dispenser/Countertop
A-2386.....	Washer - Lock ¼ Carb. Bracket
A-8730.....	Washer - Syrup Tank, Handle
A-8737.....	Washer - Syrup Tank S.S.
*.....	Water Filter See "Filter"
A-12178.....	Wire - Ground, Cabinet/Dispenser 14"
A-11750.....	Wire - Ground, 17"